

SHARP
Dot Printer

Instruction Manual

mz-80p3



SHARP CORPORATION



Note for Users in UK.

IMPORTANT

The wires in the mains lead of this apparatus are coloured in accordance with the following code:

BLUE: **Neutral**

BROWN: **Live**

As the colours of the wires in the mains lead of this apparatus may not correspond with the coloured markings identifying the terminals in your plug, proceed as follows:

- * The wire which is coloured **BLUE** must be connected to the terminal which is marked with the letter **N** or coloured **BLACK**.
- * The wire which is coloured **BROWN** must be connected to the terminal which is marked with the letter **L** or coloured **RED**.

Introduction

Thank you very much for purchasing SHARP Dot Printer MZ-80P3. Please read this instruction manual carefully before connecting this printer to the central processor MZ-80K. We hope that you will make full, longstanding use of it.

Table of Contents

	Page
● Prior to use	1
● Connection with interface unit	2
● Paper setting	2
● Operation	4
BASIC SP-5025, Disk BASIC	
MACHINE LANGUAGE SP-2001	
SYSTEMS PROGRAM	
● Printer messages	5
● Line printer printing control	5
● Character code table	6
● Printer interface specifications	7
Signal terminals	
Meanings of signal terminals	
Timing of signals	
Interface, driver and receiver	
● Ink ribbon replacement	8
● Replacement of dot head unit	9
● Printing duty	10
● Printer control flow	11
● Example of printer control subroutine (Assembly language)	12
● Specifications	16
● Precautions on use	17

Prior to use

- The mechanical part of this printer is fixed by two screws at the rear of the chassis in order to prevent damage during transit. Remove these screws before using the printer, and screw it down again when transporting it.

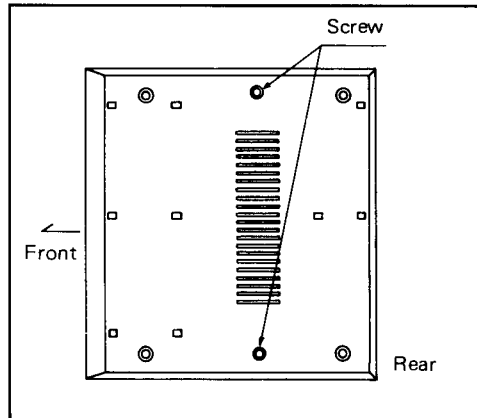

- Place the printer as horizontally as possible.
- A height difference between the fanfold paper inlet of the outer case and the face on which the end of the paper rests should be less than 1m, and the top end of the fanfold paper should be lower in height than the outer case as well; otherwise correct paper feeding cannot be expected and damage to the mechanical parts may result.

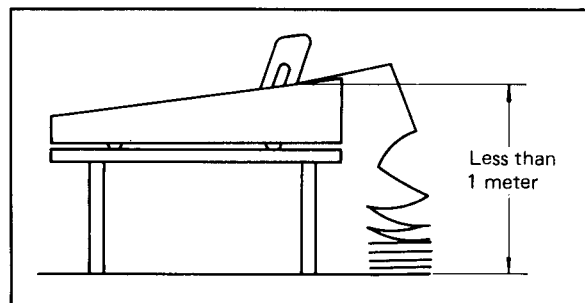

- **Do not print before the paper or the ribbon is set, otherwise the dot (printing) head is damaged.**
- Do not operate the printer when the ribbon is slack.
- No unreasonable force should be given to the dot head whilst it is in motion.
- Do not use the printer in a place that is exposed to direct sunlight or in any dusty environment.
- Since the dot head heats up during operation, do not touch it until it cools off.
- Do not rotate the paper feeding knob with the printer powered, otherwise the paper feeding mechanism may be damaged.
- **Supply voltage should be local voltage at any time. When it becomes high or low extremely, the dot head may be damaged.**
- When the power switch is turned on with the feed key switch pressed, the self-checking routine prints out all the characters in order.
- Do not press the paper feed button for longer than 2 minutes (1200 lines) continuously, or while printing.

Connection with interface unit

Insert the attached interface card into the interface unit **with its parts-fitted surface up**, as shown in Figure 2. Any of the five connectors in the interface unit will do. After the interface unit: put the flat cable of the printer in the interface unit at the rear part, then connect that flat cable to the connector of the interface card **with the polarity marks aligned** as shown in Figure 2.

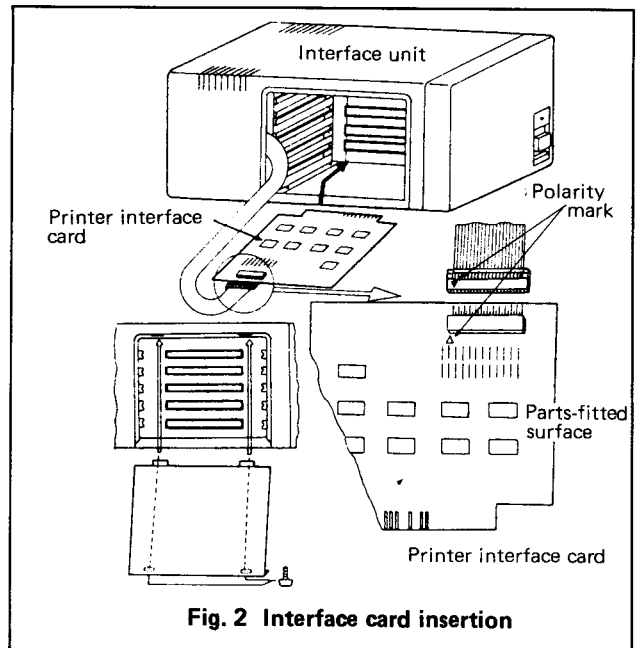
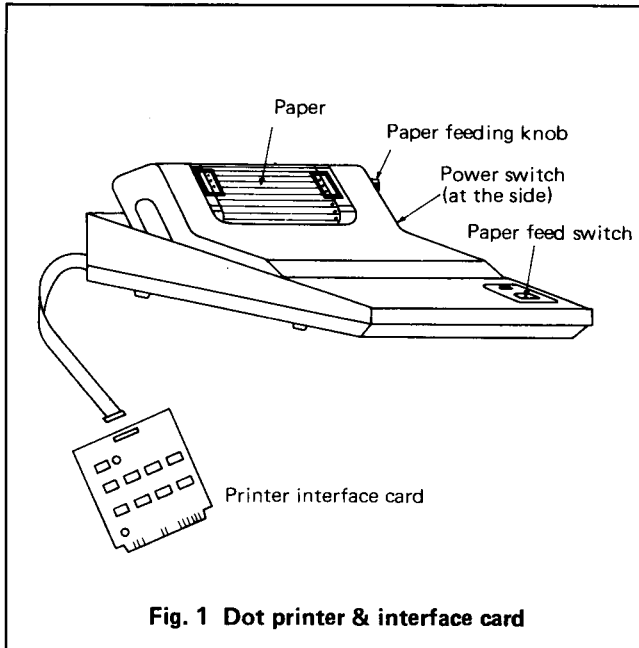

Then connect the accessory braided wire between the MZ-80K and the FG terminal of the MZ-80P3. To connect to the MZ-80K, fasten the braided wire with the screw to the left threaded hole on the rear.

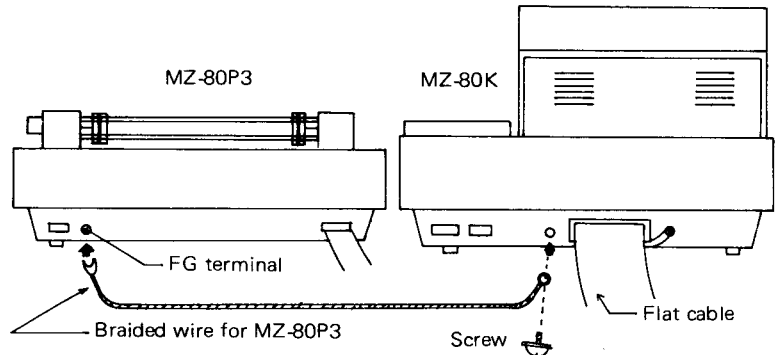

Paper setting

Use fanfold paper meeting the following specifications:

- Paper width: 101.6 to 254mm (4 to 10 inches)
In the case of printing 80 characters a line, use the paper of 254-mm width. Printing out of the paper injures the dot head.
- Paper thickness: 0.07 to 0.09mm (One sheet printing)
- Total thickness should be below 0.2mm. Copy papers should not be pasted but gathered.

Set the paper as shown in Figure 3. (For details, see Figure 4.)

- (1) Remove the acrylic cover.
- (2) Tip the tractor unit down forwards.
- (3) Insert the paper through the paper inlet.
- (4) When the paper comes out, put down the tractor unit backward; pull the paper holders up; then put the tractor pins in the holes of the paper with the paper set horizontal.

Note: Set the paper on the right and left tractor pins after running the paper through over the tractor frame support.

- (5) Put the paper holders back,; loosen the lock lever; adjust the right and left tensions of the paper; then fasten the lock lever again. (Put the lock lever down in the frontward direction to loosen it; and put it up toward the back to fasten it.)
- (6) Printing starting point adjustment:
Adjust the paper feeding knob so as to align a perforation with the top of the platen. As described hereafter, when printer control **HOM** (Home) is carried out, printing always starts at this point on every page unless the power supply is interrupted. (A distance between the top of the platen and the paper holder's centre is about 77mm. It is convenient to mark this point when making forms.
- (7) Put the acrylic cover back. This completes the paper setting.
- (8) When the printer runs short of the paper, both tractor feeding and printing stop. In the case of operating the printer in the way described hereinafter, the indication "PAPER EMPTY" appears on the TV screen of the central processor.
- (9) Do not operate the printer without setting the paper or ink ribbon.
- (10) After setting the paper, make the following checkings:
 - a) Repeat pressing and releasing the paper feed switch intermittently to check the paper is fed by a line at a time.
 - b) Keep the feed switch pressed to check the paper is continuously fed.
 - c) Use paper feeding for setting "Home" or checking printed characters.

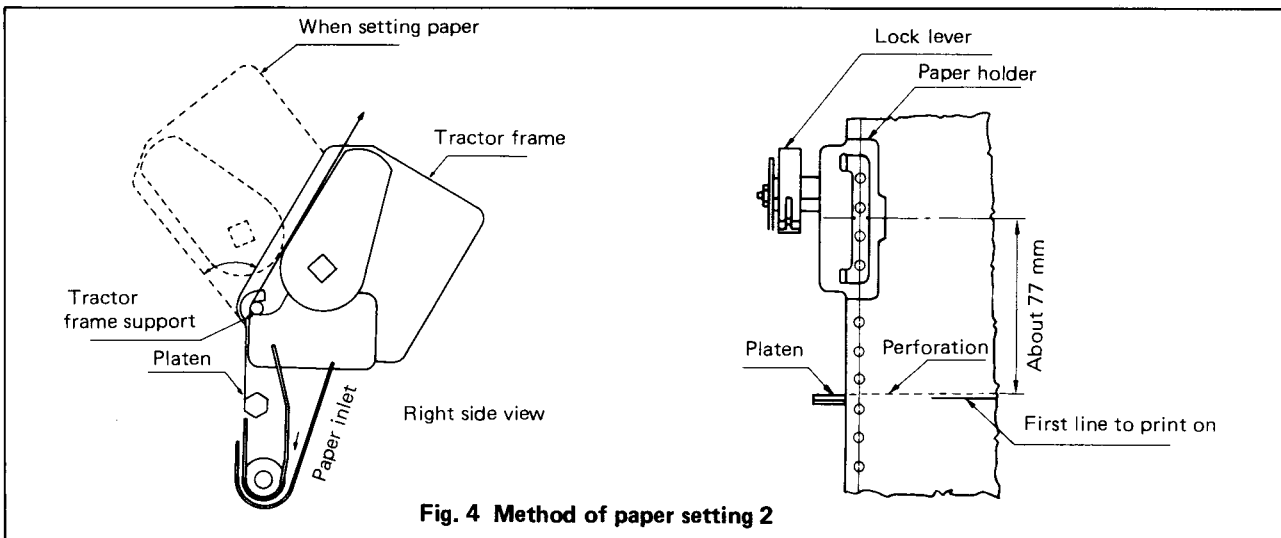
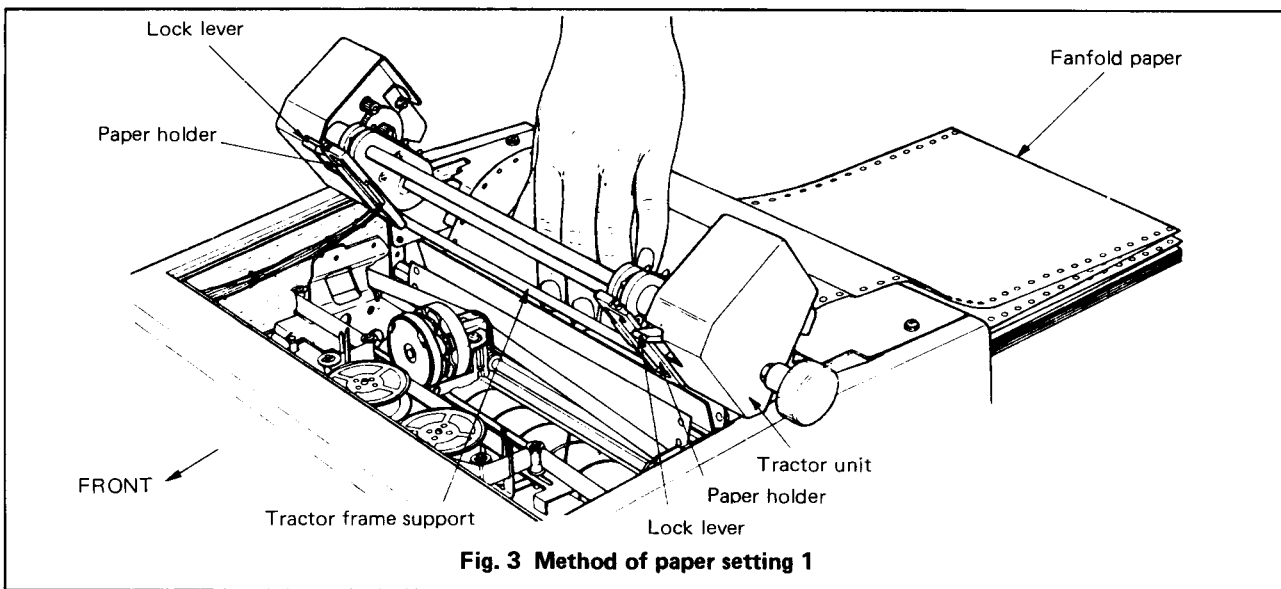

(1) BASIC SP-5025, Disk BASIC

BASIC SP-5025 and Disk BASIC have the following printer output commands:





```
LIST/P
LIST/P 70
LIST/P 70-100
LIST/P -100
```

These commands cause the printer to list the BASIC programs. Like the LIST command, they are capable of specifying statement numbers. The printer works as an 80-character line printer in the normal way of operation; so a statement occupying a space of 2 lines on the CRT screen can be listed on a single line.

```
PRINT/P A
PRINT/P A;A$, B;B$
PRINT/P "COST=";A
```

These cause the printer to print variables, details of a string of variables and strings put between quotation marks as the PRINT command shows them on the CRT screen.

However, the cursor control characters have a special function in the case of BASIC SP-5025 and Disk BASIC.

- | | | |
|---|---------------------------------|---|
|  | Paging: | Feeds the paper to the position where power has been turned on. |
|  | Line-to-line space reduction: | Use for graphic display or the like. |
|  | Double-size character printing: | Used for printing a headline. |
|  | Clear: | Clears the second and third functions above. |
|  | are disregarded. | |

Note: If more than two cursor codes are used at a time, only the code specified last is effective.

(2) MACHINE LANGUAGE SP-2001

MACHINE LANGUAGE SP-2001 carries out printer mode change by the command shown below.

```
> #
```

The printer mode is alternately set or reset by this command. When the M (memory dump) or R (register) command is executed with the printer mode in "enable", characters show up on the CRT screen and are printed out by the printer.

(3) SYSTEMS PROGRAM

In ASSEMBLER SP-2102, "PASS 3" causes the assembly list to appear on the CRT screen and to be printed by the printer.

TEXT EDITOR SP-2202, RELOCATABLE LOADER SP-2301 and SYMBOLIC DEBUGGER SP-2401 show characters on the CRT screen and makes the printer print them out, as MACHINE LANGUAGE, by putting the printer mode in "enable" using the "#" command.

Printer messages

NO POWER OR NO CONNECTION (PRINTER):

The message means that the printer is not supplied with power, or the printer is not connected to the system.

PAPER EMPTY (PRINTER):

The message means that the printer is short of the paper.

Line printer printing control

(1) This printer has a buffer memory of 80 characters capacity.

When supplied with the **CR** code from the CPU, the printer starts printing the data stored in the buffer memory, and returns to the head of a new line after completing the printing.

(2) Even when the data sent to the printer reaches up to 80 characters to fill the buffer memory, the printer does not start printing:

When the 81st character is a printable one (a character listed in the code table) or the **CR** code, the printer prints preceding the 80 characters out and advances to a new line.

When the 81st character is printable, it is recorded in the buffer memory as the first character of the next line. When the 81st character is the **CR** code, the printer goes to a new line after printing the 80-characters of data out.

(3) When the below mentioned codes are sent as the first line data from the CPU, the printer functions as follows:

CPR Line-to-line space reduction: Nullifies the space between this line and the next.
(Useful for graphic display.)

```
1234567890  
1234567890  
1234567890
```

NMR : Releases the **CPR** mode.

40C Double-size character indication: Doubles the size of characters for indication. The number of characters to a line is 40 as on the CRT screen.

```
1 2 3 4 5 6 7 8 9 0
```

NMC : Cancels the **40C** mode.

CR New line : Advances printing by one line only.

HOM Home : The position of a page when turning the power on is called "Home". When this command is executed, the paper is fed to the HOME position of the next page, and the **CPR** mode is cancelled.

(4) Any codes sent from CPU are disregarded and not recorded in the print buffer, if not listed in the code table.

Character code table (ASCII)

Shown below is an ASCII code table for the characters prepared for the dot printer. The table employs the hexadecimal notation: the codes of the upper 4 digits are shown in the columns, and the codes of the lower 4 bits in the rows. For example, the ASCII code of an alphabet character "A" is "41H" ("H" indicates the hexadecimal notation) or the ASCII code of a mark "♥" is "F3H".

A character of the dot printer consists of 6 x 7 dots, differing in configuration from that of the CRT screen. Note therefore that a character is printed as a quasi graphic pattern – not an exact copy of the picture on the CRT screen.

ASCII

MSD \ LSD		0	1	2	3	4	5	6	7	8	9	A	B	C	D	E	F
		0000	0001	0010	0011	0100	0101	0110	0111	1000	1001	1010	1011	1100	1101	1110	1111
0	0000			SP	0	@	P	☛	▣	SP	◊	q	n	SP	▣	▣	▣
1	0001	↓	!	1	A	Q	H	▣	▣	▣	a	▣	▣	▣	♠	●	
2	0010	↑	"	2	B	R	I	▣	▣	e	z	Ü	▣	▣	▣	▣	
3	0011	→	#	3	C	S	♣	▣	▣	▣	w	m	▣	▣	▣	▣	♥
4	0100	←	\$	4	D	T	♣	▣	▣	▣	s	▣	▣	▣	▣	▣	▣
5	0101	▣	%	5	E	U	♣	▣	▣	▣	u	▣	▣	▣	▣	▣	▣
6	0110	©	&	6	F	V	¥	▣	▣	t	i	▣	→	▣	▣	▣	⊗
7	0111		!	7	G	W	●	▣	▣	g	=	o	▣	▣	▣	▣	○
8	1000		(8	H	X	☺	▣	▣	h	Ö	l	▣	▣	▣	▣	♣
9	1001	CPR)	9	I	Y	☹	▣	▣	▣	k	Ä	▣	▣	▣	▣	▣
A	1010	NMR	*	:	J	Z	♣	▣	▣	b	f	ö	▣	▣	▣	▣	♦
B	1011	40C	+	;	K	□	♣	○	☹	x	v	ä	▣	▣	▣	▣	£
C	1100	NMC	,	<	L	▣	▣	▣	▣	d	▣	▣	▣	▣	▣	▣	↓
D	1101	CR	—	≡	M	▣	▣	▣	▣	r	ü	y	▣	▣	▣	▣	▣
E	1110		•	>	N	↑	▣	▣	▣	p	ß	¥	▣	▣	▣	▣	▣
F	1111	HOM	/	?	O	←	▣	▣	▣	c	j	▣	▣	▣	▣	▣	π

Table 1

Printer interface specifications

(1) Signal terminals (pins)

The connector of the printer interface card has 26 pins, and the pin numbers and signals are as follows:

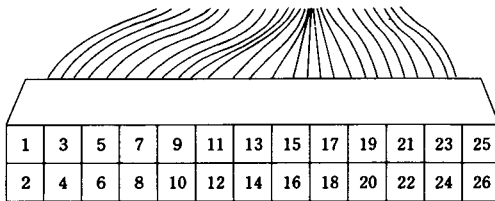

RDP	1	2	GND
RD1	3	4	GND
RD2	5	6	GND
RD3	7	8	GND
RD4	9	10	GND
RD5	11	12	GND
RD6	13	14	GND
RD7	15	16	GND
RD8	17	18	GND
IRT	19	20	GND
\overline{RDA}	21	22	GND
STATUS	23	24	GND
FG	25	26	FG

(2) Meanings of signal terminals (pins)

\overline{RDA} (RECEIVE DATA ACCEPTABLE)

The printer outputs this signal under the following conditions (Negative logic):

- (a) Power is on.
- (b) Printer is ready.

RDP (RECEIVE DATA PRESENT)

The controller outputs signals to the printer (Positive logic).

Strobing of data (RD1 ~ RD8)

DATA RD1 ~ RD8

RD1 : LSB

RD8 : MSB (Both are positive logic.)

STATUS

To status demand from the controller responds the printer when it is in the following status (Negative logic):

- (a) PAPER EMPTY
- (b) Mechanical trouble of printer

(3) Timing of signals

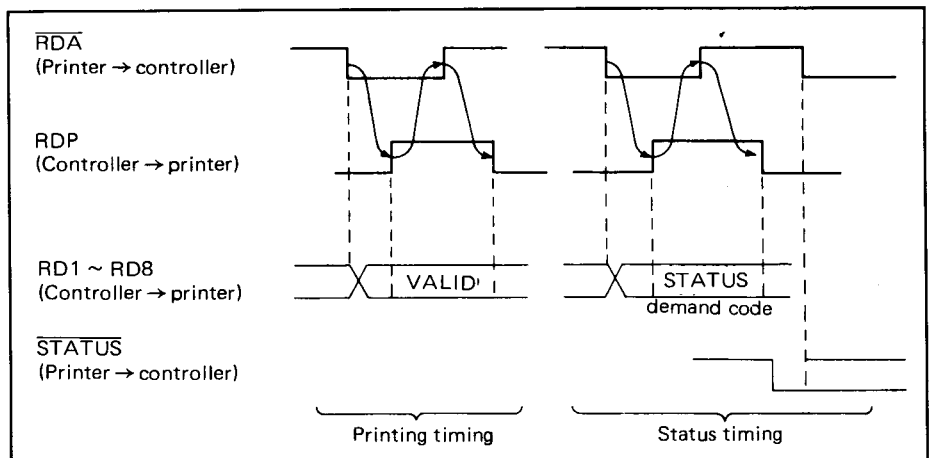

(4) Interface, driver, receiver

- (a) Interface card side (TTL level)
- (b) Printer side (TTL level)

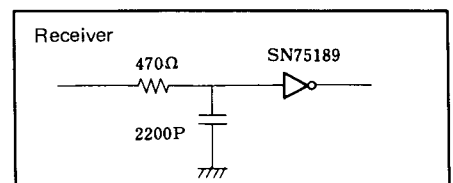
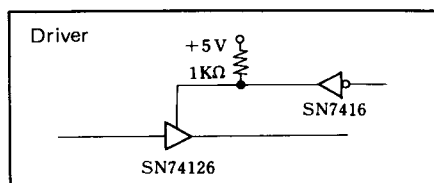
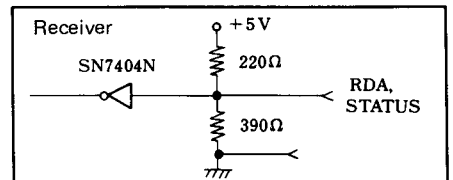
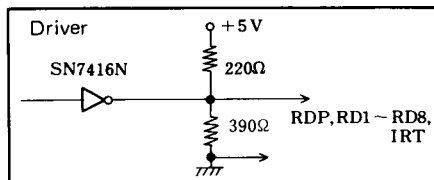

Ink ribbon replacement

(1) Ribbon removal

- (a) Lift both ribbon spools to remove them from the ribbon spool shafts.
- (b) Take the ribbon off the ribbon detection lever and ribbon guide.

(2) Ribbon setting

- (a) Set the ribbon through the ribbon setting course as shown in Figure 5.

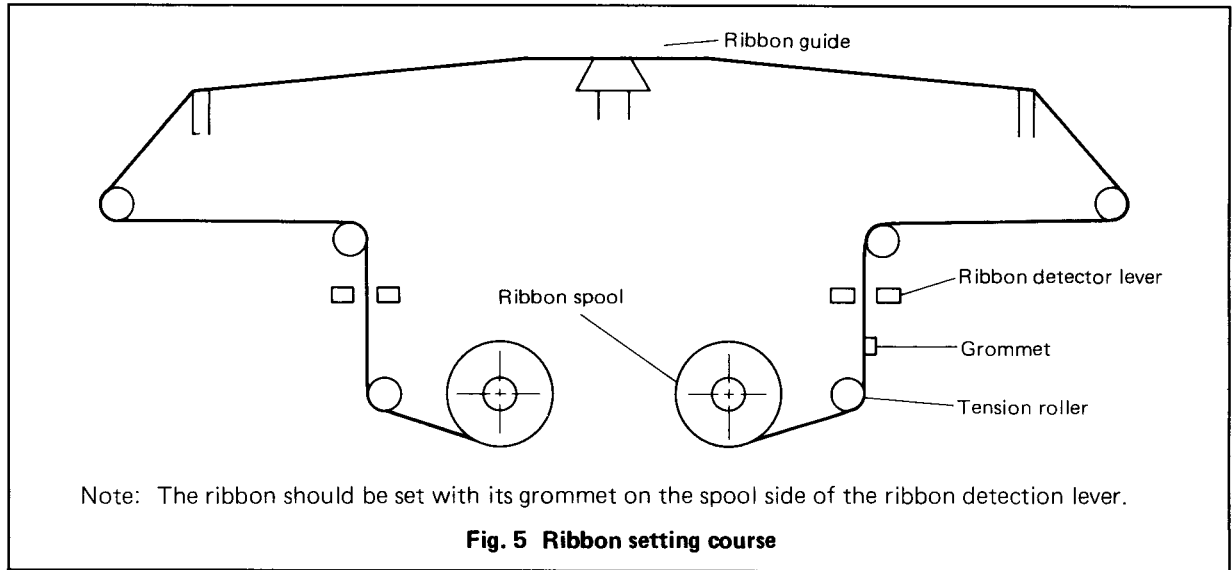

- (b) Check the ribbon spools are securely set on the ribbon spool shafts.

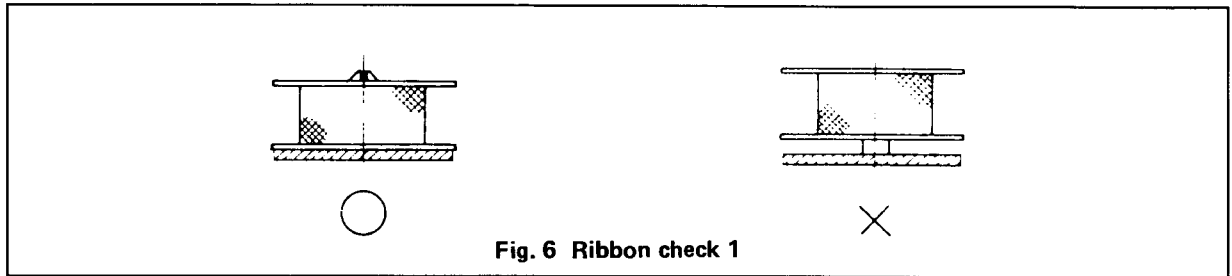

- (c) Check the ribbon is securely inserted in the ribbon detection lever and ribbon guide.

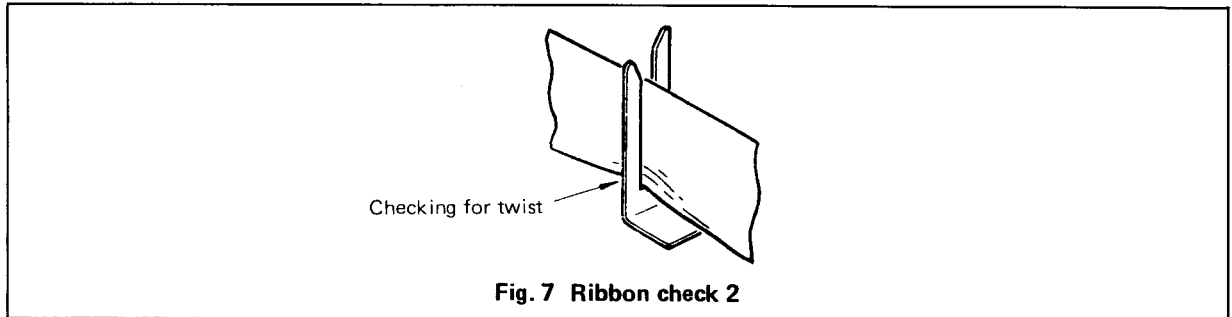

Replacement of dot head unit

The head must be replaced after printing in excess of 100-million characters. The procedure for its replacement is as follows: (Since the adjustment is quite a difficult job, it is as much better possible that it is replaced at the service center.)

(1) Removal of dot head unit.

- (a) Remove the acrylic cover.
- (b) Remove the tractor unit.
(Take off tractor rotating spring and coil spring which are hooked between the unit and the printer's main body at the right and left sides.)
- (c) Remove the grounding wire from the lower case, and the cable from the printed wiring board.
- (d) Remove two setscrews which fix the head unit to the head support. (Take care not to damage the threads.)
- (e) Take the head cord flexible printed wiring board gently out of the motor circuit printed wiring board so as not to damage them.
- (f) Remove cross recessed head machine screw (M3 x 24) from the head cord printed wiring board.

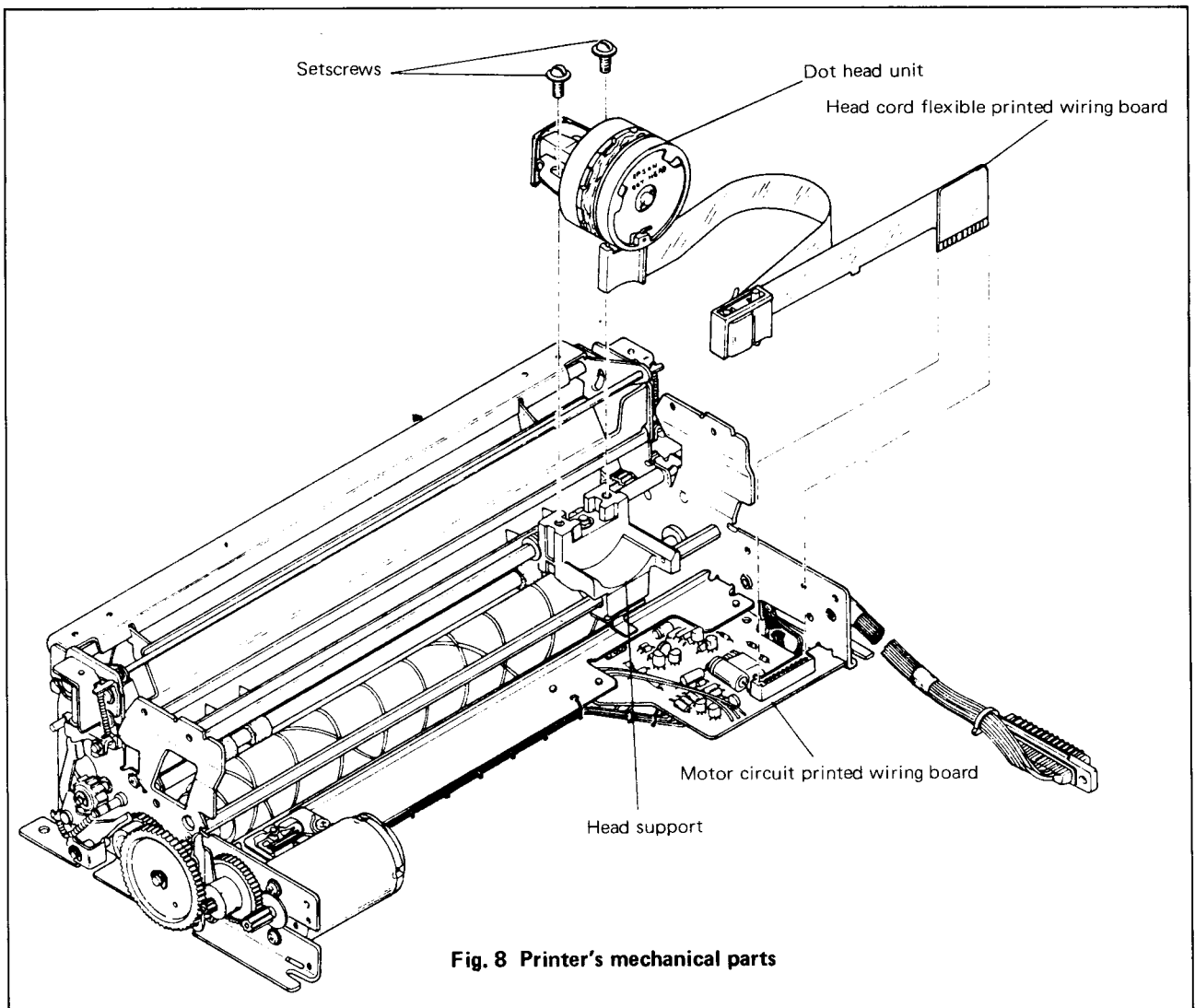
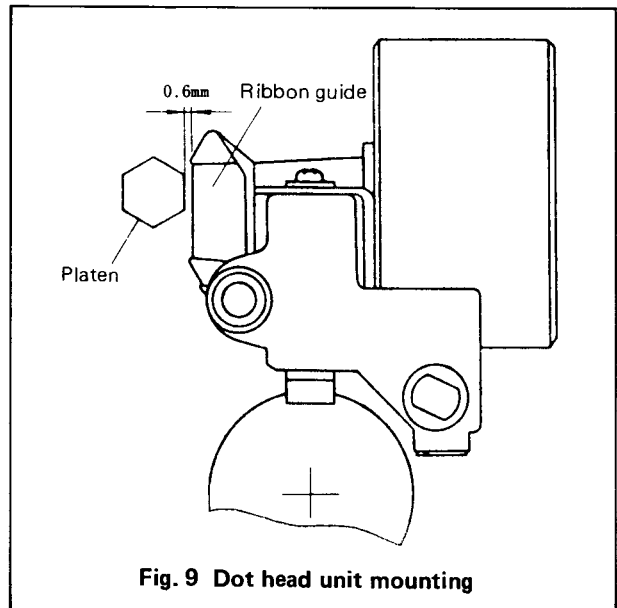

Fig. 8 Printer's mechanical parts

(2) Dot head unit mounting

- (a) Mount the dot head unit in the reverse order of its removal, and temporarily fix it using two setscrews.
- (b) Provide a clearance of 0.6mm between the platen and the ribbon guide face (the same clearance is required on the both sides of the printer), then fasten the head securely with the said screws. (The clearance adjustment should be made inserting a clearance gauge from the side of the printer.)



Printing duty

(1) At normal temperature (25° C)

In the case of continuous printing up to 15 minutes, continuous printing of 100% printing duty is possible, subject to the conditions shown below.

If the time of continuous printing is up to 15 minutes, the printing duty is 86%.

(2) At high temperature (50° C)

In the case of continuous printing within 15 minutes, continuous printing of 86% printing duty is possible.

If the time of continuous printing is over 15 minutes, the printing duty is 67%.

CONDITIONS	Font:	14 dots/character
	Printing speed:	1.2 lines/second

(3) Calculation of printing duty

The printing duty shall be 100% in the case of printing 80 characters (each of which consists of 14 dots) per line at the speed of 1.2 lines per second. The printing duty under various conditions should be calculated in proportion to the number of characters and that of dots per character.

Ex.:

In the case of over 15-minute continuous printing and font 35 dots/character (at normal temperature):

$$86\% \times \frac{14 \text{ dots/character}}{35 \text{ dots/character}} = 34.4\%$$

Therefore, 80 characters/line \times 0.344 \doteq 28 characters/line

In short, more than 28 characters should not be printed in a line in the above case.

Note:

The font designates the average number of dots required to form one character: for example, 14 dots/line indicates characters such as 2, K, etc.

Printer control flow

(1) Print character transfer flow (Control subroutine PRINT)

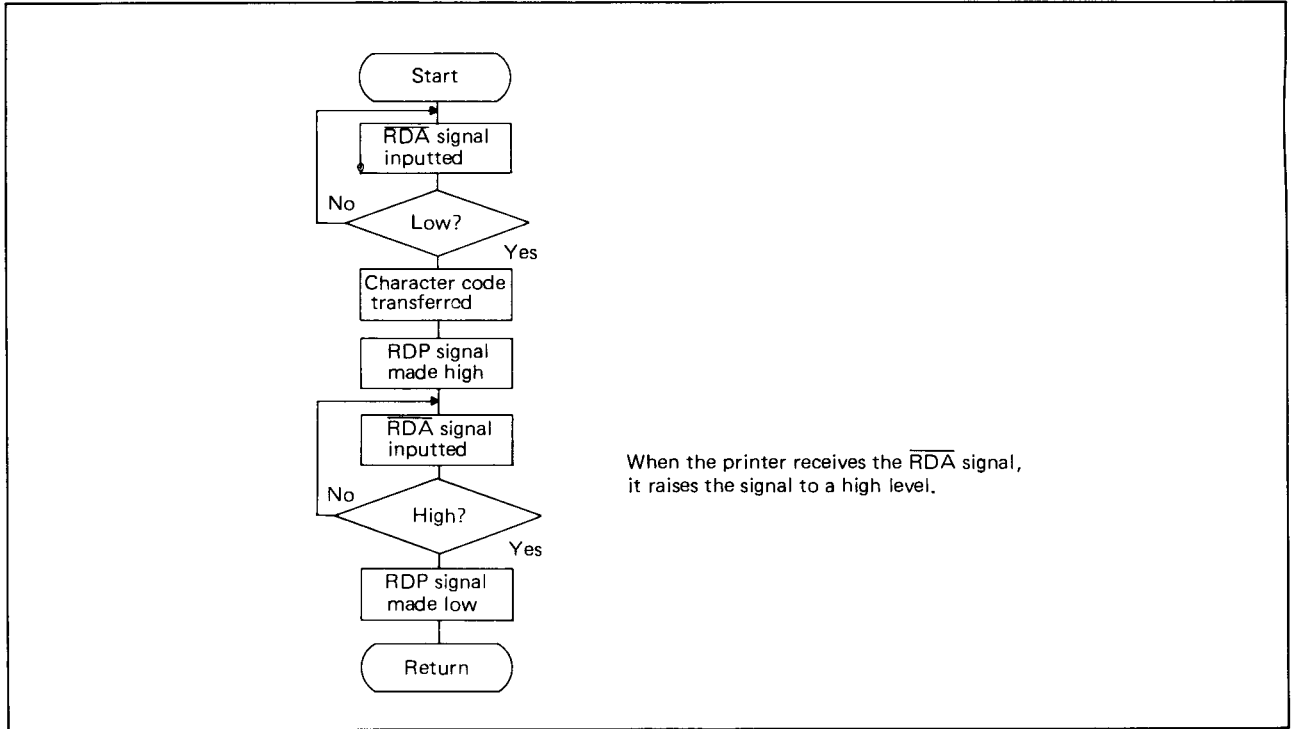

(2) Status check flow (Control subroutine STCK)

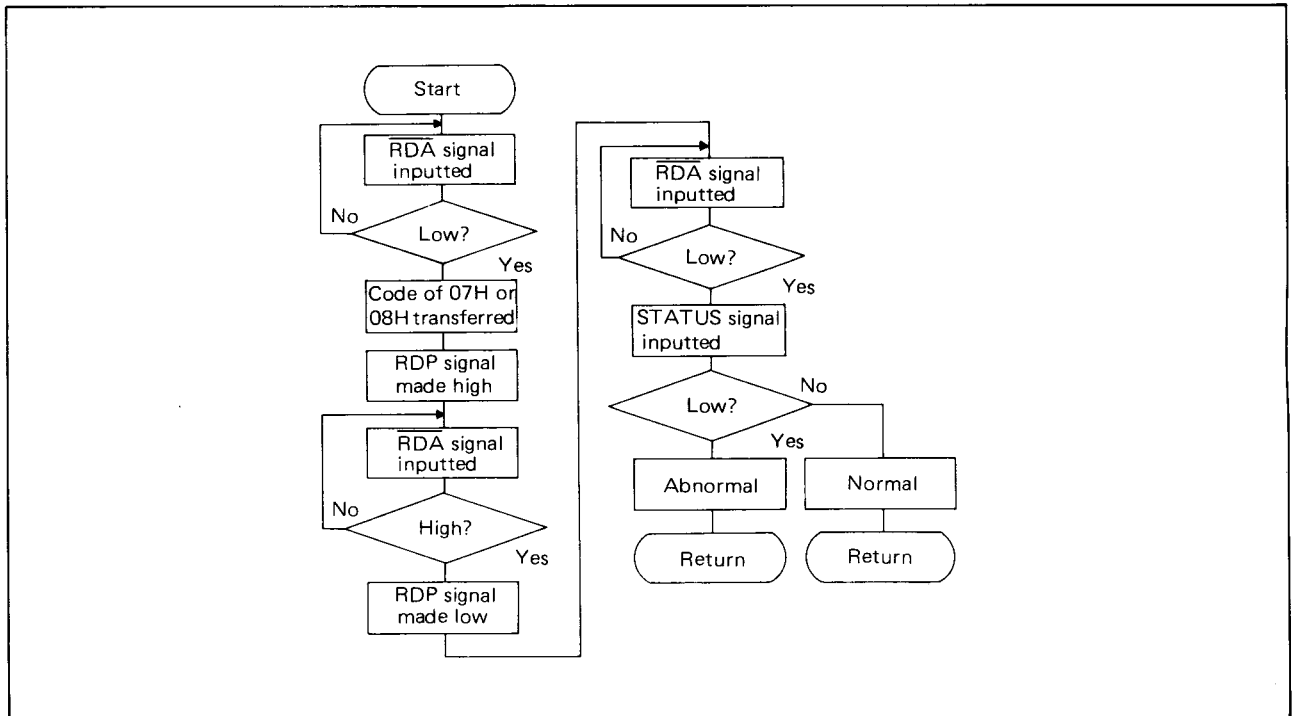

Example of printer control subroutine (Assembly language)

By calling the subroutine CPR, NMR, 40C or NMC, the corresponding printer control is carried out. When the subroutine PRINT is called, the data in the accumulator is regarded as ASCII and printed out. When the subroutine PMSGE is called, the data of the address shown by the DE register is regarded as ASCII and printed till the 0D (CR) code appears.

** Z80 ASSEMBLER SP-2102 PAGE 01 **

```

01 0000 ;;;;;;;;;;;;;;;;;;;;;;;;;;;;;;;;;;;;;;;;;;
02 0000 ;
03 0000 ; PRINTER CONTROL ROUTINE ;
04 0000 ;
05 0000 ;;;;;;;;;;;;;;;;;;;;;;;;;;;;;;;;;;;;;;;;;;
06 0000 ;
07 0000 ; PRINT CONTROL
08 0000 ;
09 0000 ;;;;;;;;;;;;;;;;;;;;;;;;;;;;;;;;;;;;;;;;;;
10 0000 ;
11 0000 ; GRAPHIC PRINT MODE
12 0000 ;
13 0000 3E09 CPR: LD A,09H ; CPR CODE
14 0002 CD2400 CALL PRINT
15 0005 C9 RET
16 0006 ;
17 0006 ; CPR CLEAR
18 0006 ;
19 0006 3E0A NMR: LD A,0AH ; NMR CODE
20 0008 CD2400 CALL PRINT
21 000B C9 RET
22 000C ;
23 000C ; DOUBLE WIDTH PRINT MODE
24 000C ;
25 000C 3E0B 40C: LD A,0BH ; 40C CODE
26 000E CD2400 CALL PRINT
27 0011 C9 RET
28 0012 ;
29 0012 ; 40C CLEAR
30 0012 ;
31 0012 3E0C NMC: LD A,0CH ; NMC CODE
32 0014 CD2400 CALL PRINT
33 0017 C9 RET
34 0018 ;
35 0018 ; CARRIAGE RETURN
36 0018 ;
37 0018 3E0D LD A,0DH ; CR CODE
38 001A CD2400 CALL PRINT
39 001D C9 RET
40 001E ;
41 001E ; HOME CODE
42 001E ;
43 001E 3E0F HOM: LD A,0FH ; HOM CODE
44 0020 CD2400 CALL PRINT
45 0023 C9 RET
46 0024 ;
47 0024 ; SKP H

```

```

01 0024          ;
02 0024          ;
03 0024          ;   ACC PRINT
04 0024          ;
05 0024 F5      PRINT:  PUSH  AF
06 0025 CD4100  CALL   ?PRNT
07 0028 CD8900  CALL   STCK
08 002B F1      POP   AF
09 002C C9      RET
10 002D          ;
11 002D          ;   MESSAGE PRINT
12 002D          ;   DE=DATA LOW ADR
13 002D          ;   (END=CR CODE)
14 002D          ;
15 002D F5      PMSG1:  PUSH  AF
16 002E D5      PUSH  DE
17 002F 1A      LD     A,(DE)
18 0030 CD4100  CALL   ?PRNT
19 0033 1A      LD     A,(DE)
20 0034 FE0D    CP    0DH
21 0036 2803    JR    Z,PMSG2
22 0038 13      INC   DE
23 0039 18F4    JR    PMSG1
24 003B CD8900  PMSG2:  CALL   STCK
25 003E D1      POP   DE
26 003F F1      POP   AF
27 0040 C9      RET
28 0041          ;
29 0041          ;   PRINT
30 0041          ;
31 0041 F5      ?PRNT:  PUSH  AF
32 0042 3E00    LD     A,0H          ;READY CHECK
33 0044 CD5700  CALL   RDA
34 0047 F1      POP   AF
35 0048 D3FF    OUT   (POTFF),A     ;DATA OUT
36 004A 3E80    LD     A,80H
37 004C D3FE    OUT   (POTFE),A     ;POP HIGH
38 004E 3E01    LD     A,01H        ;RDA CHECK
39 0050 CD5700  CALL   RDA
40 0053 AF      XOR   A
41 0054 D3FE    OUT   (POTFE),A     ;RDP LOW
42 0056 C9      RET
43 0057          SKP   H

```

```

01 0057      ;
02 0057      ;   RDA CHECK
03 0057      ;
04 0057 D9   RDA:   EXX
05 0058 57   LD     D,A
06 0059 010000 LD    BC,0000H   ;ACC=COMPARE DATA
07 005C DBFE RDA1:  IN    A,(POTFE) ;TIMER SET
08 005E E60D AND    0DH
09 0060 BA   CP    D
10 0061 2002 JR    NZ,4
11 0063 D9   EXX
12 0064 C9   RET
13 0065      ;
14 0065 1E10 LD    E,10H
15 0067 1D   DEC    E
16 0068 20FD JR    NZ,-1
17 006A 0B   DEC    BC
18 006B 78   LD    A,B
19 006C B1   OR    C
20 006D 20ED JR    NZ,RDA1
21 006F D9   EXX
22 0070 CD0900 CALL NL
23 0073 11A100 LD    DE,MSG1
24 0076 CD1500 CALL MSG
25 0079 C30000 E      JP    ABNML   ;ABNORMAL JUMP
26 007C      ;
27 007C      ;   STATUS INPUT
28 007C      ;
29 007C CD4100 STIN:  CALL ?PRNT
30 007F 3E00 LD    A,0H
31 0081 CD5700 CALL RDA
32 0084 DBFE IN    A,(POTFE)
33 0086 0F   RRCA
34 0087 0F   RRCA
35 0088 C9   RET
36 0089      ;
37 0089      ;   STATUS CHECK
38 0089      ;
39 0089 3E07 STCK:  LD    A,07H   ;PAPER CHECK
40 008B CD7C00 CALL STIN
41 008E D8   RET    C       ;NOMAL RETURN
42 008F      ;
43 008F 11C300 STCK1: LD    DE,MSG2
44 0092 CD0900 CALL NL
45 0095 CD1500 CALL MSG
46 0098 11B900 LD    DE,MSG11
47 009B CD1500 CALL MSG
48 009E C30000 E      JP    ABNML   ;ABNORMAL JUMP
49 00A1      SKP    H

```

```

01 00A1 4E4F2050      MSG1:  DEFM  'NO POWER'
02 00A5 4F574552
03 00A9 4F52204E      DEFM  'OR NO CONNECTION'
04 00AD 4F20434F
05 00B1 4E4E4543
06 00B5 54494F4E
07 00B9 28505249      MSG11: DEFM  '(PRINTER)'
08 00BD 4E544552
09 00C1 29
10 00C2 0D
11 00C3 50415045      MSG2:  DEFB  0DH
12 00C7 5220454D      DEFM  'PAPER EMPTY'
13 00CB 505459
14 00CE 0D            DEFB  0DH
15 00CF                ;
16 00CF P            POTFF: EQU  FFH
17 00CF P            POTFE: EQU  FEH
18 00CF                ;
19 00CF P            NL:    EQU  0009H
20 00CF P            MSG:   EQU  0015H
21 00CF                END

```

```

40C    000C  ?PRNT  0041  CPR      0000  HOM      001E  MSG      0015
MSG1    00A1  MSG11  00B9  MSG2    00C3  NL       0009  NMC      0012
NMR     0006  PMSG1  002F  PMSG2   003B  PMSGE    002D  POTFE    00FE
POTFF   00FF  PRINT  0024  RDA     0057  RDA1     005C  STCK     0089
STCK1   008F  STIN   007C

```

Specifications

Item	Specifications
Printing method Feed method Printing capacity Kinds of printed characters Character make-up Size of character Printing speed	Serial dot matrix method Tractor feed method 80 characters/line 40 characters/line (Double-size character display) 226 kinds (See the code table) excluding the space code 6 x 7 dots 12 x 7 dots (Double-size character display) Width: 2.2 mm Height: 3.1 mm About 1.2 lines/sec (at 25°C)
Line-to-line space Head sweep direction	2.54 mm (in normal mode) Left → Right
Used code	8 bits CR (New line) code is 0DH.
Spare part Operation switches Interface Life of printer mechanism	Head unit Power supply & paper feeding Conforming to Bandminton interface MCBF 5 million lines (excl. of head's life)
Print recording paper Ink ribbon	(1) Kind: Fanfold paper (2) Size: (Width) 102 to 254 mm (4 to 10 inches) Note: In the case of printing 80 characters per line, use paper of 254 mm width. (Thickness) Below 0.2 mm (total thickness) Copy possible Ribbon is automatically fed by motor. (1) Color: Single (Black) (2) Material: Nylon (with eyelet) (3) Size: 13 mm (W) x 11,000 mm (L) (4) Life: About 2 million letters Note: If other ink ribbon than the above mentioned one is used, quality of printed characters, life of ribbon and head may deteriorate.
Power supply Power consumption Working temperature Working humidity Storage temperature Storage humidity Outer dimensions Weight	Local voltage 50Hz 85 W 5 to 40°C 10 to 80% (No dew-condensation) -20 to 50°C 5 to 85% (No dew-condensation) 410 (W) x 385 (D) x 198 (H) (mm) 10.6 kg

Specifications and appearance subject to change without prior notice.

Precautions on use

★ Supply voltage

- Use this printer with the local supply voltage. Extremely high or low supply voltage may result in trouble, and its satisfactory performance cannot be expected, and the dot head will be damaged.
- Separate the AC power line from other apparatus (large-scale motor, etc.) which cause noise.

★ Power cord

Be sure not to damage the power cord by pressing it under a desk or chair, or by nipping it. The use of a damaged power cord is dangerous. Pull the power cord out of the wall outlet by holding the plug.

★ Humidity and dust

Do not place the printer in a place where humidity is high (such as in a bath room, kitchen or the like) or where there is much dust.

★ High temperature

Do not place this unit where there is direct sunlight or near heating apparatus. They may damage the cabinet and inner parts.

★ Water and foreign matter

It is dangerous to use this unit with water or other liquids, or needle(s), pin(s) or other metallic objects contained inside. If water or other liquid, in particular, gets into the unit, remove the cord plug from the wall outlet immediately and contact your dealer.

★ Shock

This machine consists of precision electronic parts. Do not hit it or give it any physical shocks.

★ When not used for a long time

If the unit is not used for a long period of time, be sure to remove the power cord's plug from the wall outlet.

★ Stain

Lightly wipe stain off the unit using a soft cloth soaked with water or detergent. The use of benzine, thinner or other volatile matter or an insecticide may result in discoloring the outer case.

★ Installation

Do not use this machine where temperature is extremely higher or low, where temperature change is great, or where there is much vibration or dust. Do not put any objects on this unit.

Sharp Corporation has all rights of MZ-80 series.

No part of this publication may be reproduced or transmitted in any form or by any means, without the permission of Sharp Corporation.

