

SHARP SERVICE MANUAL

MZ-80SFD

PDSMX81014-MZ

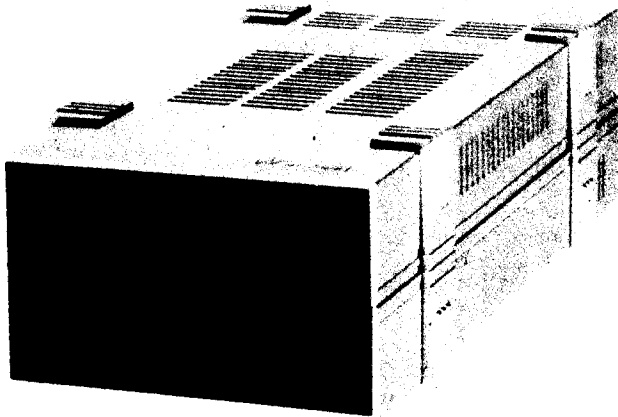

Single Floppy Disk MZ-80SFD

FEATURES

- High speed reading and writing of data and programs.
- Easy deletion and addition of programs.
- Simultaneous reading and execution of program by "RUN" command.
- Linking programs by "CHAIN, SWAP" command.
- Expanding up to four drives by one I/O card.

SHARP CORPORATION

Contents

Specifications	1
Constitution of single floppy	1
Operational principle of floppy disk	2
Inspection and replacement of disk drive main parts	6
Trouble shooting guide	11
Power supply section	13
Circuit diagram and printed wiring board	15
Packing method	20
Disassembled views	21
Replacement parts list	23

SPECIFICATIONS

■ General specifications

Item	Specification
Drive-to-drive connection	Daisy-chain system (a maximum of four drives)
Recording medium	5.25-inch both-sides flexible disk
Recording	Double or single density
Number of tracks	70 tracks
Sector	Soft sectored
Formatted capacity	280K bytes/drive at 16 sectors/track (double density) 140K bytes/drive at 16 sectors/track (single density)
Power supply	AC 220V \pm 10%, 50Hz AC 240V \pm 10%, 50Hz
Power Consumption	30W
Operating conditions	5 to 25°C in temperature 20 to 80% in humidity (free of moisture condensation)
External dimensions	Approx. 165 (W) x 102 (H) x 323 (D) mm
Weight	4 kg

■ Power supply section specifications

Item	Specification
Input	AC 220V \pm 10%, 50Hz AC 240V \pm 10%, 50Hz
Output	DC 12V DC5V

* Specifications and design subject to change without prior notice for product improvement. In such cases, items mentioned above may be partially different from the product.

CONSTITUTION OF SINGLE FLOPPY

■ Constitution and Block Diagram

MZ-80SFD is constituted by floppy disk drive unit, control PWB unit, terminal resistor PWB unit and power supply unit.

Its floppy disk drive is the same as the drives used for MZ-80FD/MZ-80FDK/MZ-80FB/MZ-80FBK.

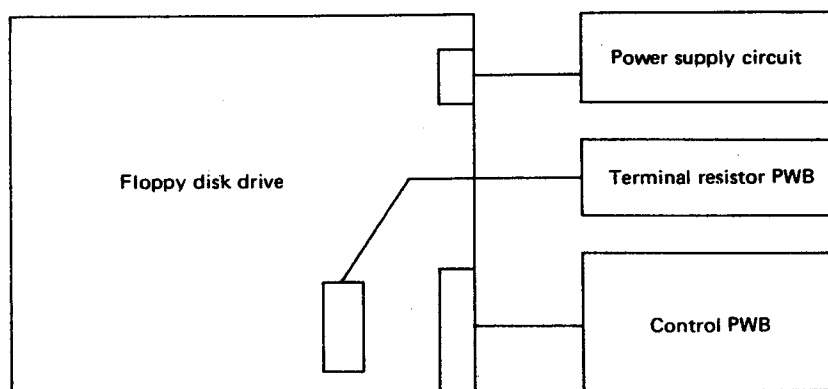

Block diagram

OPERATIONAL PRINCIPLE OF FLOPPY DISK

The floppy disk is designed to rotate the so-called "diskette," a magnetic disk storage unit, to read out and write in data at high speeds by bringing the

magnetic head in direct contact with a specified track sector of 70 tracks formed in both surfaces of the diskette.

1. Fundamental block diagram

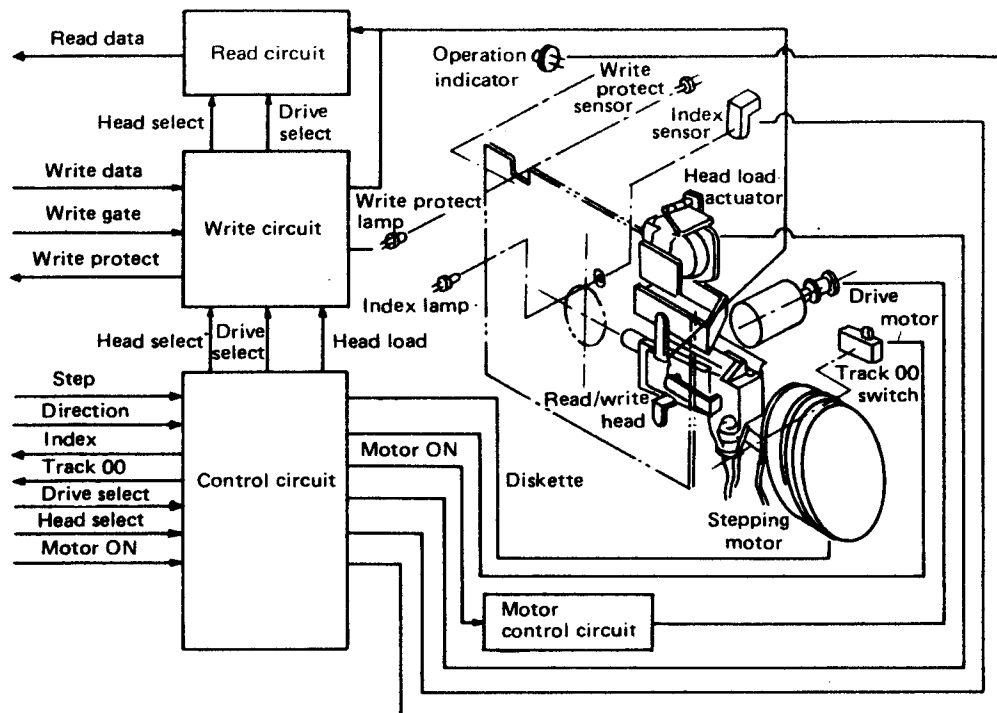

2. Mechanism explanation

This device consists mainly of the following mechanisms.

1) Read/write head

The head is attached to the arm through a leaf spring. The head can follow the motion of diskette easily.

Signals read out of the head are transmitted through FPC (Flexible Printed Cable) to the read amp. circuit.

2) Carriage assembly

2 units of read/write head are mounted on the carriage. The carriage is located with the stepping motor and lead screw.

3) Head locating mechanism

This is a high-precision, reliable head locating mechanism using stepping motor and screw-driven ball/V-groove system.

The stepping motor is of 7.5° /pulse, steel plate type.

One pulse of step signal causes a 2-step rotation by 15° , thus pushing forward the head by one track.

4) Diskette driving mechanism

A small-sized DC motor with tachogenerator is employed. The motor rotation is transmitted through the drive belt, spindle pulley and spindle hub, thereby causing rotation of the diskette. This spindle pulley is provided with a stroboscope to check rotation interval.

5) Head load mechanism

This is a mechanism in which the head is brought into contact with the diskette. It is operated by the head load actuator.

6) Write protect detection section

A luminous diode and a photo-transistor are used to detect write protect notch of the diskette and jacket. (Writing is not possible when the notch is covered with label.)

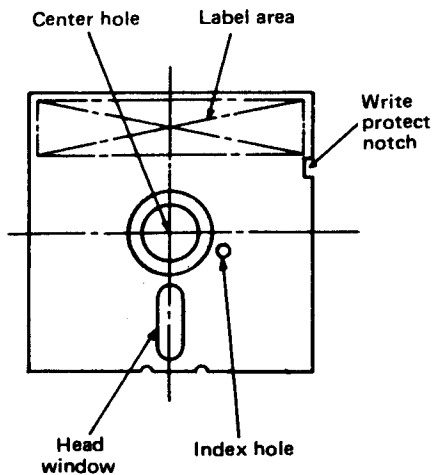

Description of diskette parts

7) Index detection section

This section consists of a luminous diode and a phototransistor. An index hole of the diskette is detected by this section to determine the starting point of a track.

8) Track 00 detection section

A carriage position is detected with a limit switch. When the carriage has reached the track 00 point, track 00 signal is emitted.

9) Control electronics section

The electric circuit to control each mechanism is composed of 2 sheets of PWB. One is to control the DC motor control circuit. The other is to control other circuits, say, detection and other functions with respect to read/write, step, head load, and other signals.

10) Diskette protect mechanism

Shutting the front door, with the diskette incompletely set in, can give damage to the diskette, thus shortening its life-time. To prevent such a drawback, this mechanism has been adopted so that the front door cannot be closed if the diskette is improperly in.

3. Interface

1) Interface signal

All lines are of TTL (transistor-transistor logic).

(1) Input signals

For input signals there are 10 kinds of input lines, all of which are valid at low levels. These signal lines are terminated at a 150-ohm integrated resistor fitted in the IC socket of drive 1. The signal voltage levels are as follows.

High level	Invalid	2.4 to 5.25V
Low level	Valid	0 to 0.4V
Input impedance		Pull-up to 5V at 150-ohm resistor

① Drive select signals (0 to 3)

MZ-80SFD is connectable up to 4 units.

These signals are used to select a desired one of the four drive units.

At low levels of drive select signal, R/W head is loaded to cause the operation indicator to light up.

Note)

The drive requires to be set with a drive select switch to meet the position of use (Drive No. 1 thru 4).

② Motor ON signal

The drive motor starts when the signal level becomes low. This signal level becomes high about 2 seconds after completion of all operations, if no operation is commanded next. It thus interrupts the motor, extending the service life of motor.

③ Direction select signal

The signal is given to designate the shifting direction of R/W head, when the step pulse is input.

High level - - - Out direction (to diskette outer portion)

Low level - - - IN direction (to diskette center)

④ Step signal

This signal is given to move the R/W head in the direction designated by the direction select signal. The operation is done in the course of changing from low levels to high levels.

⑤ Write data signal

This signal is used to write in data on the diskette. Each time changing high levels to low levels, the current flowing in the R/W head is reversed to write in data bit.

This write-in performance is available when write gate signal is at low levels.

⑥ Write gate signal

This signal being at low levels, data can be written on the diskette. At high levels, read-out or sequential operation may be made.

⑦ Side 1 select signal

This signal is given to decide which side of a double-face diskette to read or write. The R/W head of side 0 and that of side 1 are selected at high levels and low levels, respectively.

(2) Output signals

There are the following four kinds of output signal.

① Index signal

By this signal the starting position of each track can be detected. Each time the index hole of diskette is detected with the detector, the track is fed from the drive unit.

Usually, this signal level becomes low each time the hole is detected at high levels. Therefore, the leading edge of the signal indicates the beginning of a track.

② Track 00 signal

The low-level state of this signal signifies that the R/W head is located at track 00 position (the outermost track).

In any position other than track 00, the signal is at high levels.

When the R/W head is at track 00, the head is held at the position by the stopper even if another signal to step outside is given. At this time, however, the track 00 signal level becomes high. By adding still another signal to step outside, the motor phase is returned to cause track 00 signal to become low.

③ Write protect signal

This signal is used to detect whether or not write protect for the diskette is provided. When a diskette with write protect is in, the signal level becomes low.

In usual operation, a diskette with write protect enables to protect write statement within the drive.

④ Read data signal

The signal is given to transfer data read from the diskette. Usually it is at high levels, while during detection it comes down to low levels.

3) Timing

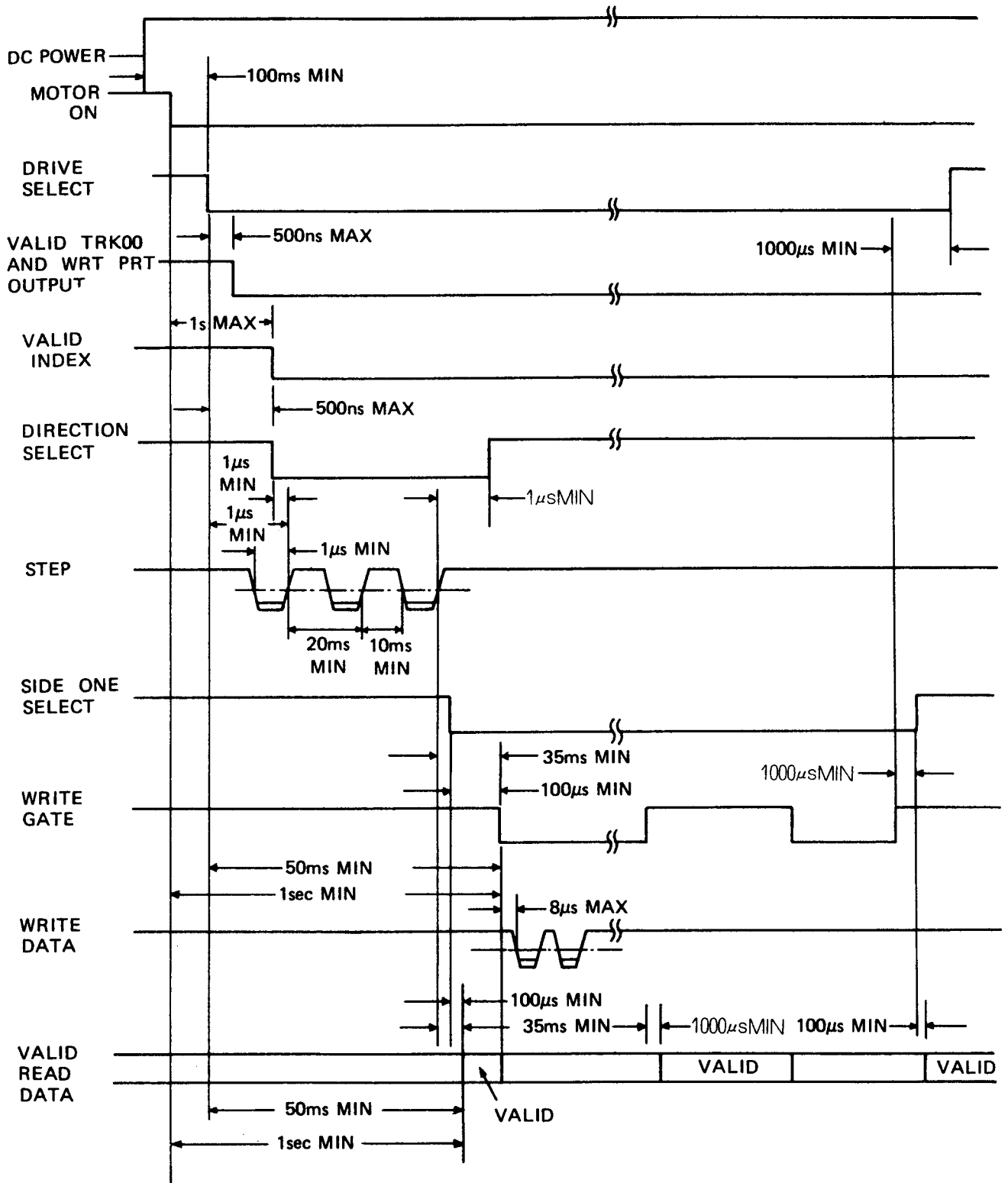

Control and data timing

2) Power supply unit interface

Specified supply voltage of DC 5V/DC 12V is fed from the power supply unit to the J2 connector of drive control PWB.

INSPECTION AND REPLACEMENT OF DISK DRIVE MAIN PARTS

1. Belt

1) Inspection

Check to see if the belt is stained with dust or dirt. Also make sure that there is no unevenness, scratch and thinned part.

2) Replacement

- 1) Take the belt off the spindle pulley while rotating the pulley gradually by hand.
- 2) For applying the belt, put the belt first on the motor pulley and then on the spindle pulley while rotating the spindle pulley.

Note)

1. In putting on and off the belt, be careful so that it be not caught by the motor pulley flange.
2. Note that there is no difference between both sides of a new belt.

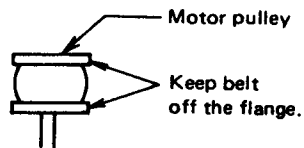

2. PWB unit

1) Replacement

- 1) Take connectors J3 and J4 off PWB.
- 2) Remove 3 PWB unit fixing screws (3 mm).
- 3) Detach PWB unit.
- 4) For reassembly, take the reverse order.

Note)

In replacing PWB unit, it is necessary to check which short pins to cut and whether or not terminal resistor is required, depending on which drive unit to use (DRIVE No.).

- Short pin: Detach the short pins from the old PWB unit and apply them to a new PWB.
- Terminal resistor: If the old PWB unit has no terminal resistor, remove terminal resistor from a new PWB.

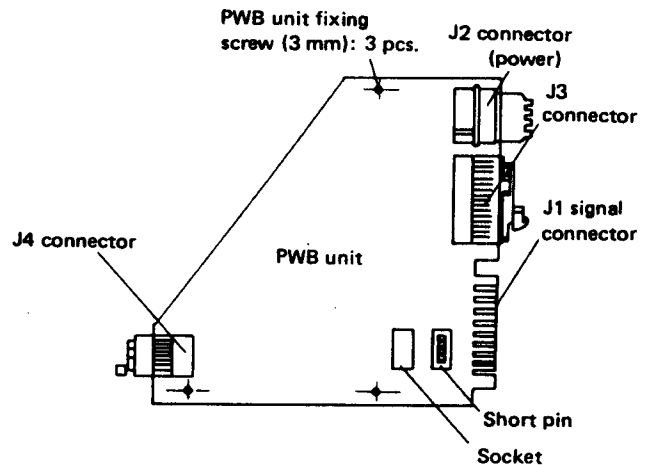

3. Index lamp assembly

1) Inspection

- ① Connect power socket to connector J2 of PWB unit. Turn power on.
- ② Make sure that there is a voltage range of DC 1 to 1.7V between B-11 (lower white lead of the 11th pin from power socket) and A-11 (black lead of the 11th pin from power socket), both belonging to connector J3.

2) Replacement

- ① Remove PWB unit (refer to page 6).
- ② Disconnect 2 lead wires of index lamp assembly from the housing of connector J3.
- ③ Cut off the tie band fixing lead wires of index lamp assembly (be careful not to damage lead wires), and open the front door.
- ④ Take lead wires off the guide groove of carrier, and draw out the index lamp assembly with tweezers and fingers.
- ⑤ To attach, take the reverse order.
- ⑥ Carry out inspection, referring to description at left.

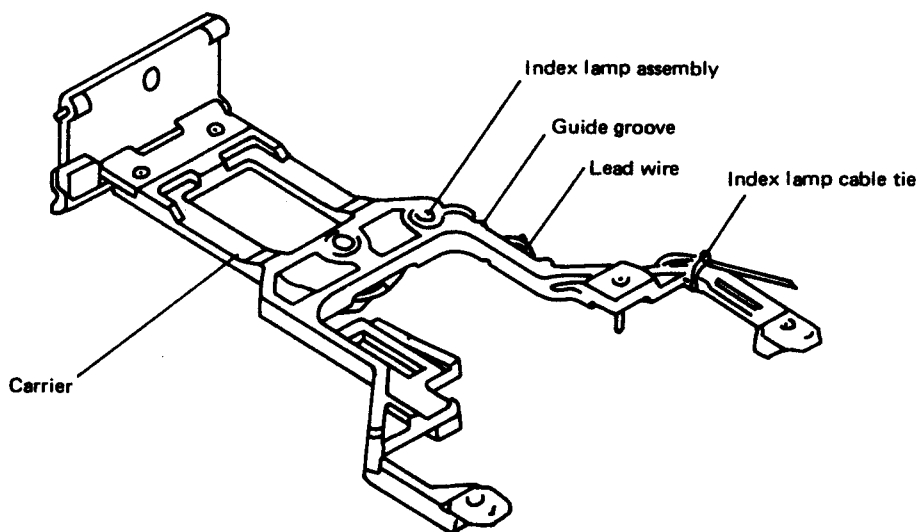

Note)

When attaching the index lamp assembly to the carrier, fit the housing and LED in at the same time.

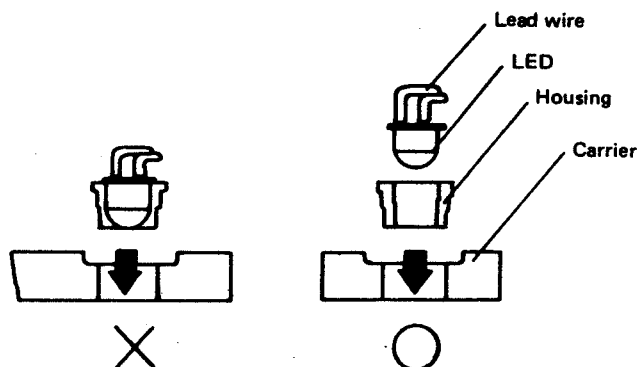

4. Media guide L assembly (with write protect sensor lamp)

1) Inspection

- ① Connect power socket to connector J2 of PWB unit. Turn power on.
- ② Before inserting a diskette, check the following items.
 - a) Write protect lamp
Make sure that there is a voltage range of DC 1 to 1.7V between B-13 (lower yellow lead of the 13th pin from power socket) and A-13 (black lead of the 13th pin from power socket), both belonging to connector J3.
 - b) Write protect sensor
Make sure that there is a voltage range of DC 0 to 0.5V between B-14 (orange lead below the 14th pin from power socket) and A-14 (black lead of the 14th pin from power socket), both belonging to connector J3.
- ③ Put a write protect diskette (with write protect seal being applied at the write protect notch of diskette) in place, and shut the front door. Then check the following item.
 - Write protect sensor
Make sure that there is a voltage range of DC 2.5 to 5.25V between B-14 and A-14 of connector J3.

2) Replacement

- ① Remove PWB unit (refer to page 6).
- ② Open the front door.
- ③ Detach 4 lead wires of media guide L assembly from the housing of connector J3.
- ④ Remove 2 media guide L assembly fixing screws (3 mm) and take out the assembly.
- ⑤ To attach, take the reverse order.
- ⑥ Carry out inspection, referring to description at left.

Note)

1. Attach the media guide L assembly by pushing it to main frame stopper side and front bezel side.
2. Lamp and sensor cannot be individually replaced, because they are built in the media guide L assembly.

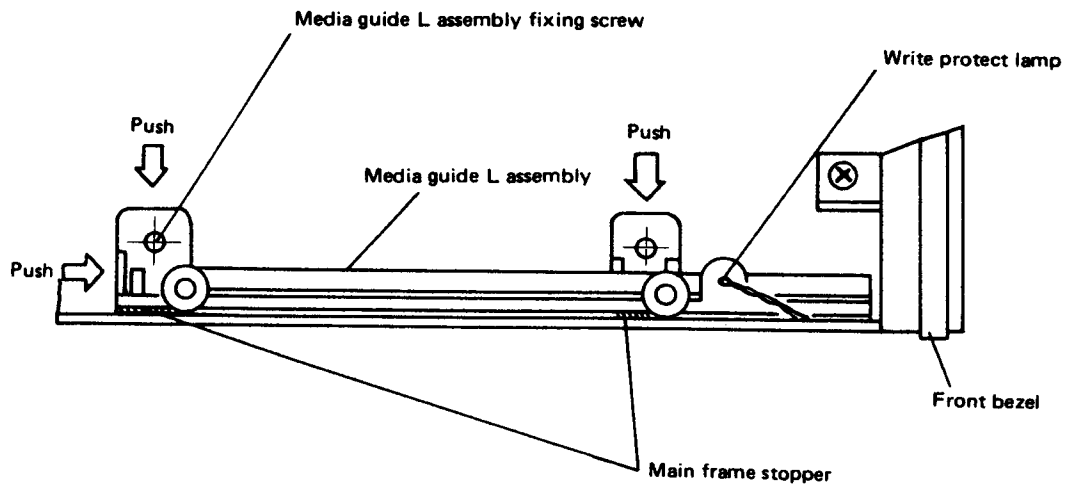

5. Operation indicator

1) Inspection

- ① Connect power socket to connector J2 of PWB unit and turn power on.
- ② Let drive select 0 of interface signals be at low levels (make a short between J1-8 terminal of PWB and PWB Ground), and make short pin DSO circuit shorted. (Do not prolong this test.)

Note that the voltage range between connector J3-B10 (red lead of the 10th pin from power socket) and J 3-A10 (upper black lead of the 10th pin from power socket) will be DC 1 to 2V when the lamp is lit.

2) Replacement

- ① Remove PWB unit (refer to page 14).
- ② Detach 2 lead wires of operation indicator from the housing of connector J3, and take lead wires out of the wire holder.
- ③ Open the front door.
- ④ Remove 2 front bezel fixing screws (3 mm) and the front bezel itself by pulling it forward.
- ⑤ Draw out the holder 2 with tweezers in the arrow direction. Take out LED holder. (See the sketch at right.)
- ⑥ Draw LED out of the LED holder. To assemble, take the reverse order.
- ⑦ Carry out inspection, referring to the above instruction.

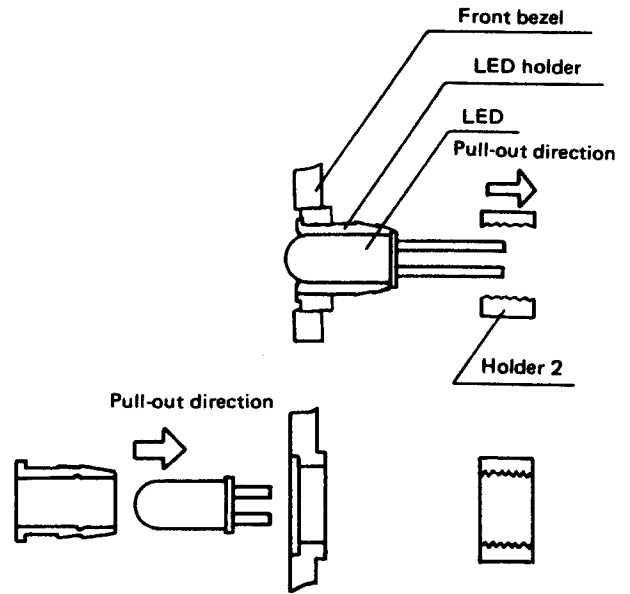

Note:

1. Attach the front bezel assembly, by pushing it to main frame side and main frame stopper. (See the sketch below.)
2. Do not pull up the carrier with fingers, otherwise excessive force is applied to the head arm.

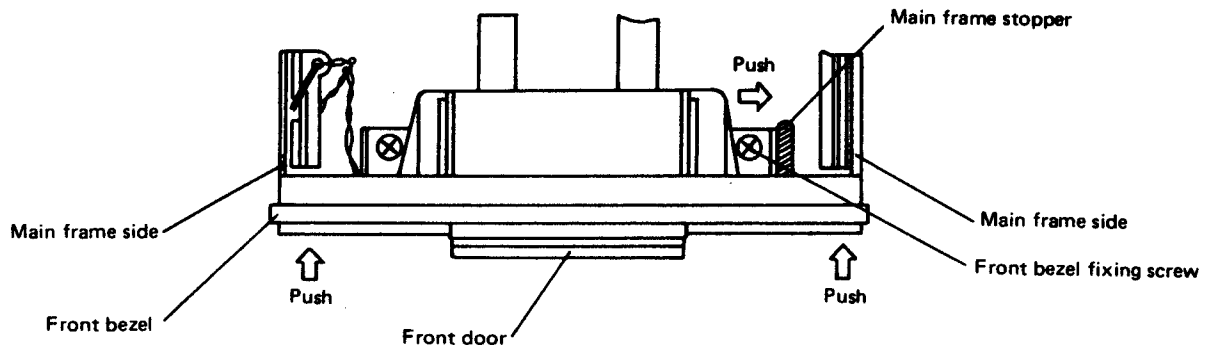

6. Drive motor assembly (DC motor and motor control PWB unit)

1) Inspection

- ① Connect power socket to connector J2 of PWB unit. Turn power on.
- ② Led interface motor ON signals be at low levels (make a short between J1-16 terminal of PWB unit and PWB Ground) and run the motor. (Do not prolong this test.)
- ③ Put a diskette in place and close the front door.
- ④ Carry on head load.
- ⑤ Make sure that the stroboplate attached on the spindle pulley appears to be stationary.

Note)

The shifting rate of stroboplate is allowed to be up to 1.5 pcs./sec.

2) Replacement

- ① Remove PWB unit. (Refer to page 6.)
- ② Put off the belt. (Refer to page 6.)
- ③ Cut off the tie band for fixing lead wires of motor and motor control PWB unit. Be careful not to damage lead wires.
- ④ Remove 3 lead wires—coming from the motor control PWB unit to connector J3—from the housing of connector J3.
- ⑤ Remove 2 motor control PWB unit fixing screws (3 mm) and 2 DC motor fixing screws (3 mm). Detach the DC motor and motor control PWB unit from the main frame.
- ⑥ For assembly, take the reverse order.
- ⑦ Carry out inspection, referring to description at left.

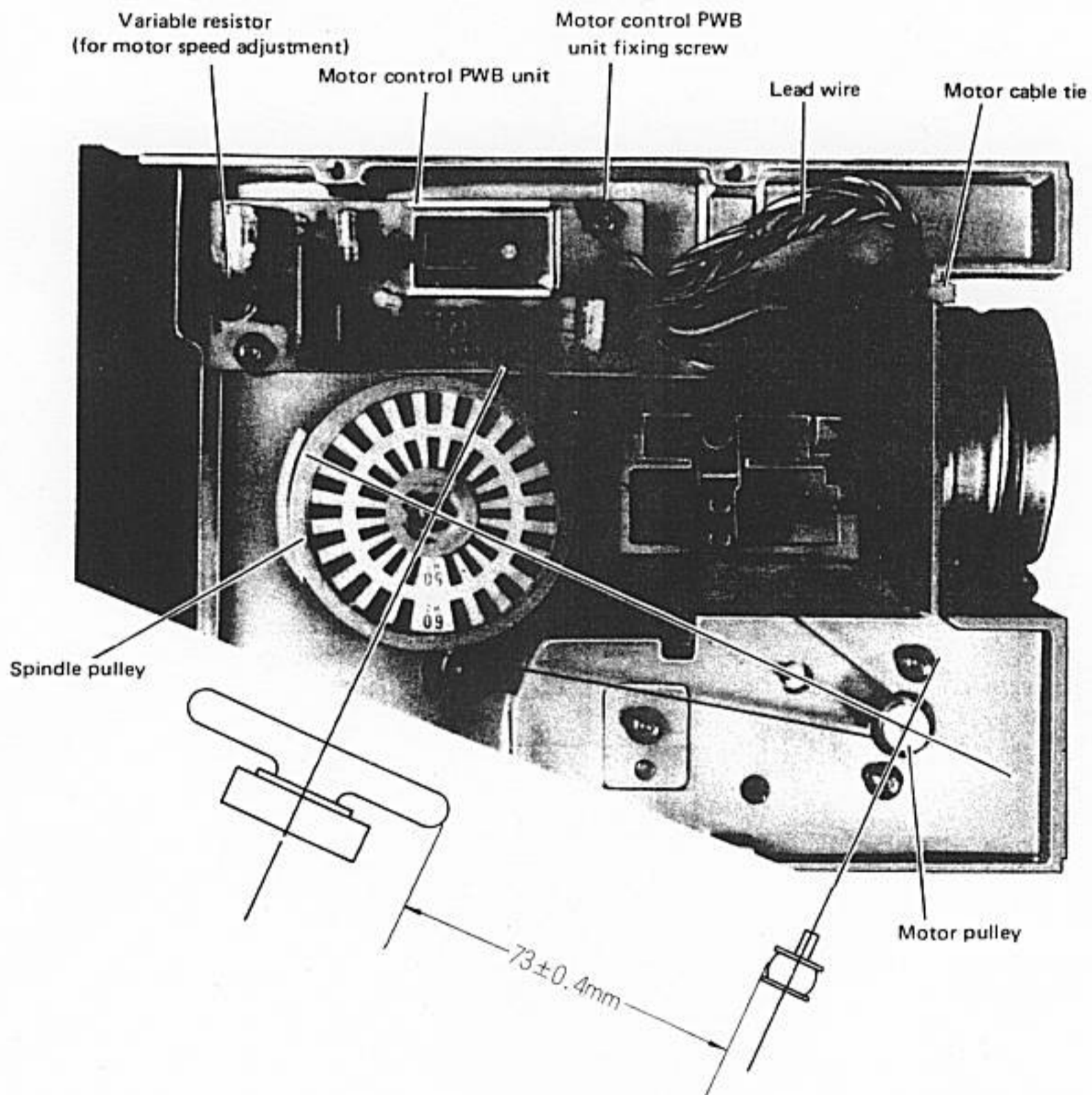

Note)

In mounting the DC motor, the distance between spindle pulley and motor pulley should be kept to be $73 \pm 0.4 \text{ mm}$ as shown above.

3) Adjustment

- ① After the completion of the above check items, adjust the variable resistor of motor control PWB unit so that the stroboplate appears to be completely stationary.

TROUBLE SHOOTING GUIDE

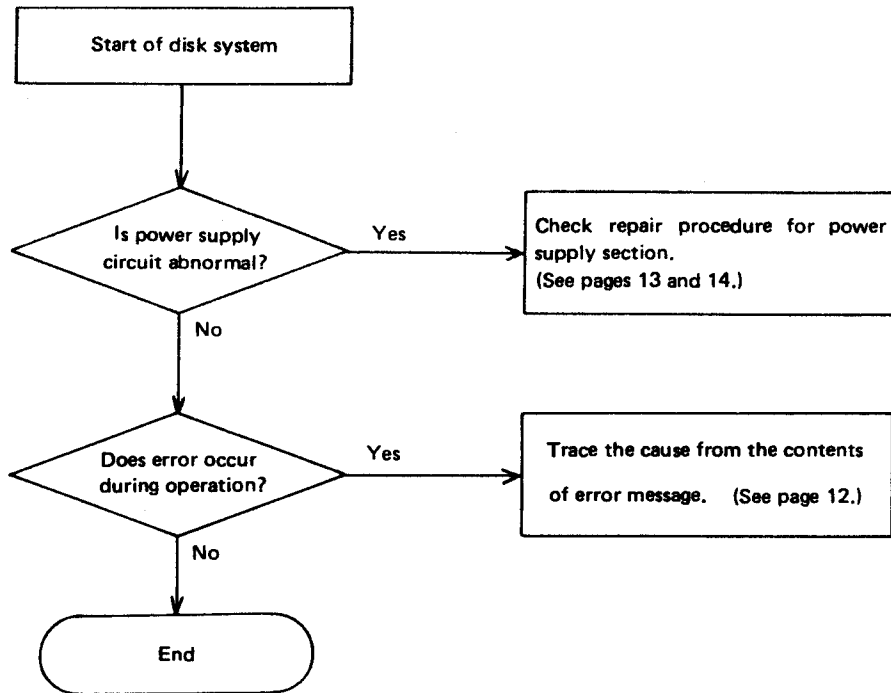

- Check by replacing several sheets of diskette to see if errors occur due to faulty diskette (data deterioration caused by foreign matters, deformation, wear-out, damage, magnetism, etc.).
- Troubles in disk system often cause error messages. Trace the cause from the contents of error message.
- Replace suspected parts in the disk system with normal ones. Check again the trouble section.
 - 1) Personal computer
 - 2) Interface unit or expansion port
 - 3) I/O card
 - 4) Diskette
 - 5) Signal cable
 - 6) Disk drive
- The signal circuits of floppy disk and I/O card operate at TTL levels of 0V, +5V. Connect any system other than micro-computer peripheral devices for MZ-80 series to see if signal levels are out of the range of 0 to +5V (max. +5.25V).
- The disk drive needs a RAM area of more 36K bytes. If the RAM area of your machine is less than 36K bytes, it must be expanded.

■ Error chart for disk system

Error code [Error message]	Contents	Check item and corrective action
50 [NO READY]	1) Drive fails to be ready. <input type="checkbox"/> Diskette is wrongly inserted. <input type="checkbox"/> Motor does not normally run. <input type="checkbox"/> Index detection circuit is improper. <input type="checkbox"/> Flat cable is improperly fit in or broken. <input type="checkbox"/> No select signal comes at drive. <input type="checkbox"/> Drive unit door (front door) is not closed. <input type="checkbox"/> Diskette is faulty. <input type="checkbox"/> Write operation is attempted in write protect state.	<input type="checkbox"/> Fit diskette in correctly. <input type="checkbox"/> Check belt and/or drive motor assembly. <input type="checkbox"/> Check index lamp, drive PWB, index sensor. <input type="checkbox"/> Check flat cable. <input type="checkbox"/> Check floppy disk I/O card. <input type="checkbox"/> Close front door. <input type="checkbox"/> Replace diskette.
54 [UNFORMAT]	1) Drive <input type="checkbox"/> Head position is not aligned. (off-track state) <input type="checkbox"/> Head and amp. circuit are defective.	<input type="checkbox"/> Replace drive unit. <input type="checkbox"/> Replace drive unit and/or drive PWB unit.
	2) Diskette <input type="checkbox"/> Diskette not formatted is in use. <input type="checkbox"/> CRC error in ID field. <input type="checkbox"/> ID field is broken down.	<input type="checkbox"/> Initialize again, or replace diskette
41 [DISK DATA ERROR]	1) Drive <input type="checkbox"/> SEEK error <input type="checkbox"/> Head shift is improper.	<input type="checkbox"/> Check drive unit and diskette Replace, if required. <input type="checkbox"/> Replace drive unit.
	2) Diskette <input type="checkbox"/> CRC error in data field. <input type="checkbox"/> Data field is broken down. <input type="checkbox"/> ID field is defective. <input type="checkbox"/> Data mark detection error.	<input type="checkbox"/> Initialize again, or replace diskette.

POWER SUPPLY SECTION

Block Diagram of Power Supply Section

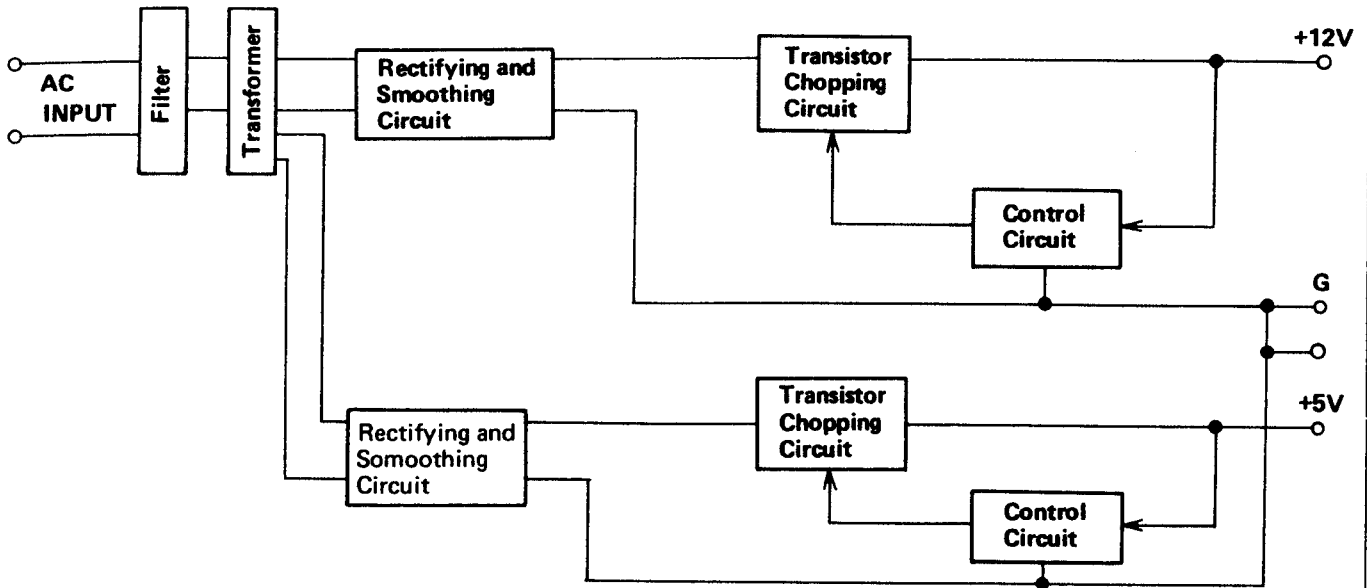

Waveform of Each Part

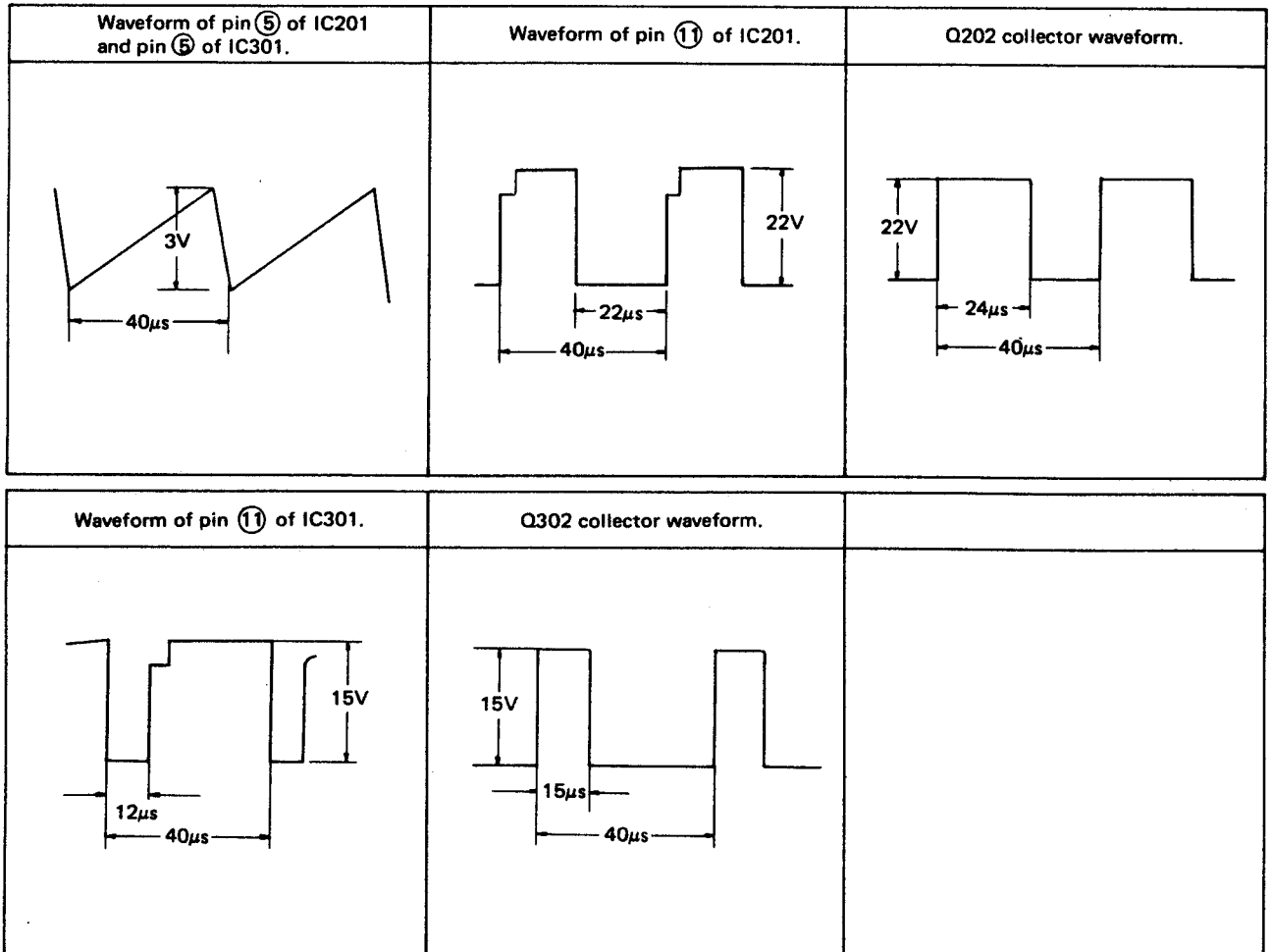

■ Trouble Shooting Chart

Problem 1: No voltage appears at any output terminal.

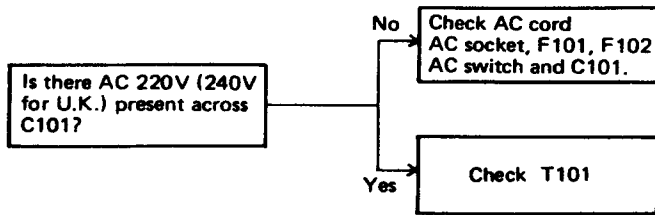

Problem 2: +12V is not developed.

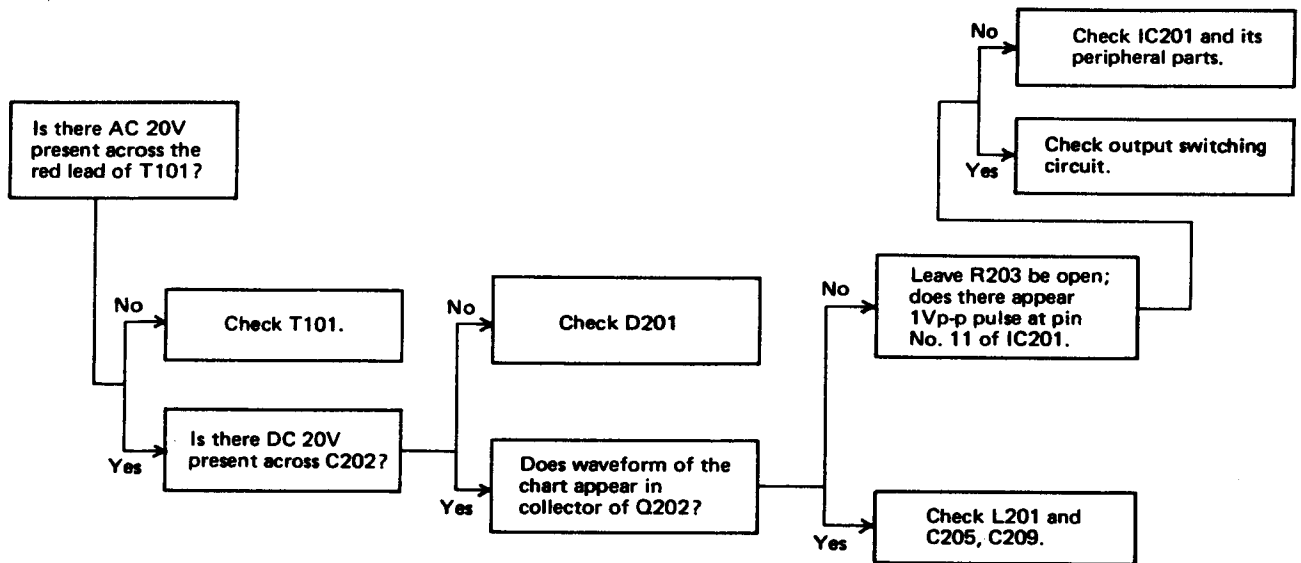

Problem 4: +5V is not developed.

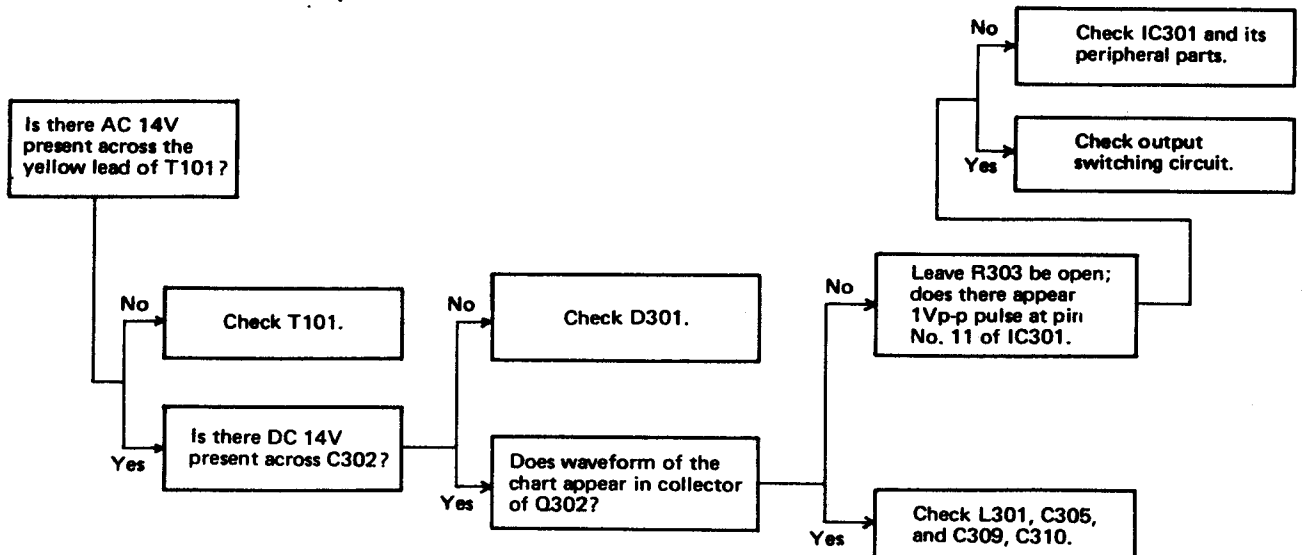

CIRCUIT DIAGRAM AND PRINTED WIRING BOARD

Notes: The circuit diagram and printed wiring board are subject to change without prior notice.

■ Power Supply Circuit

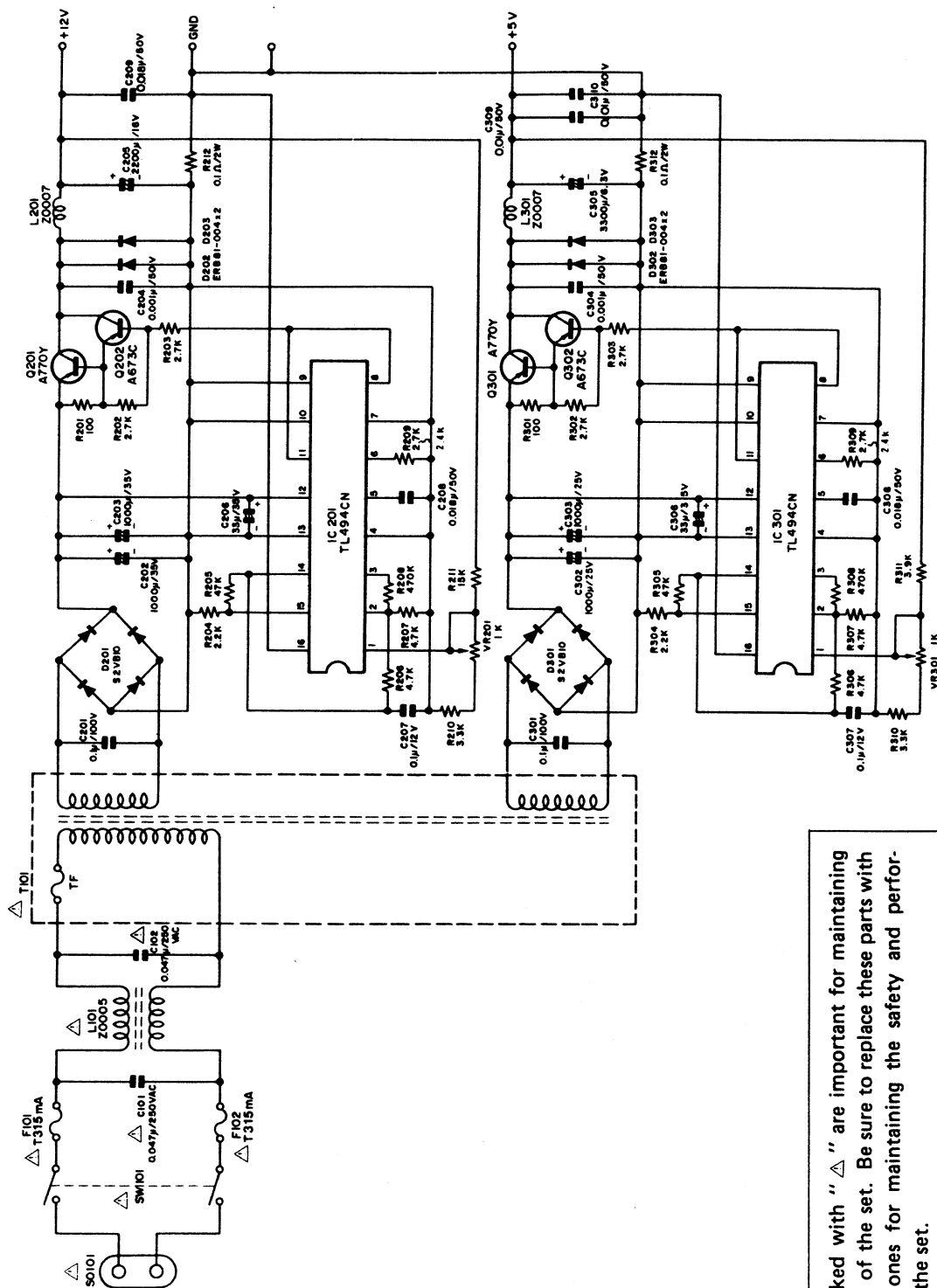

Parts marked with "△" are important for maintaining the safety of the set. Be sure to replace these parts with specified ones for maintaining the safety and performance of the set.

■ Power Supply PWB

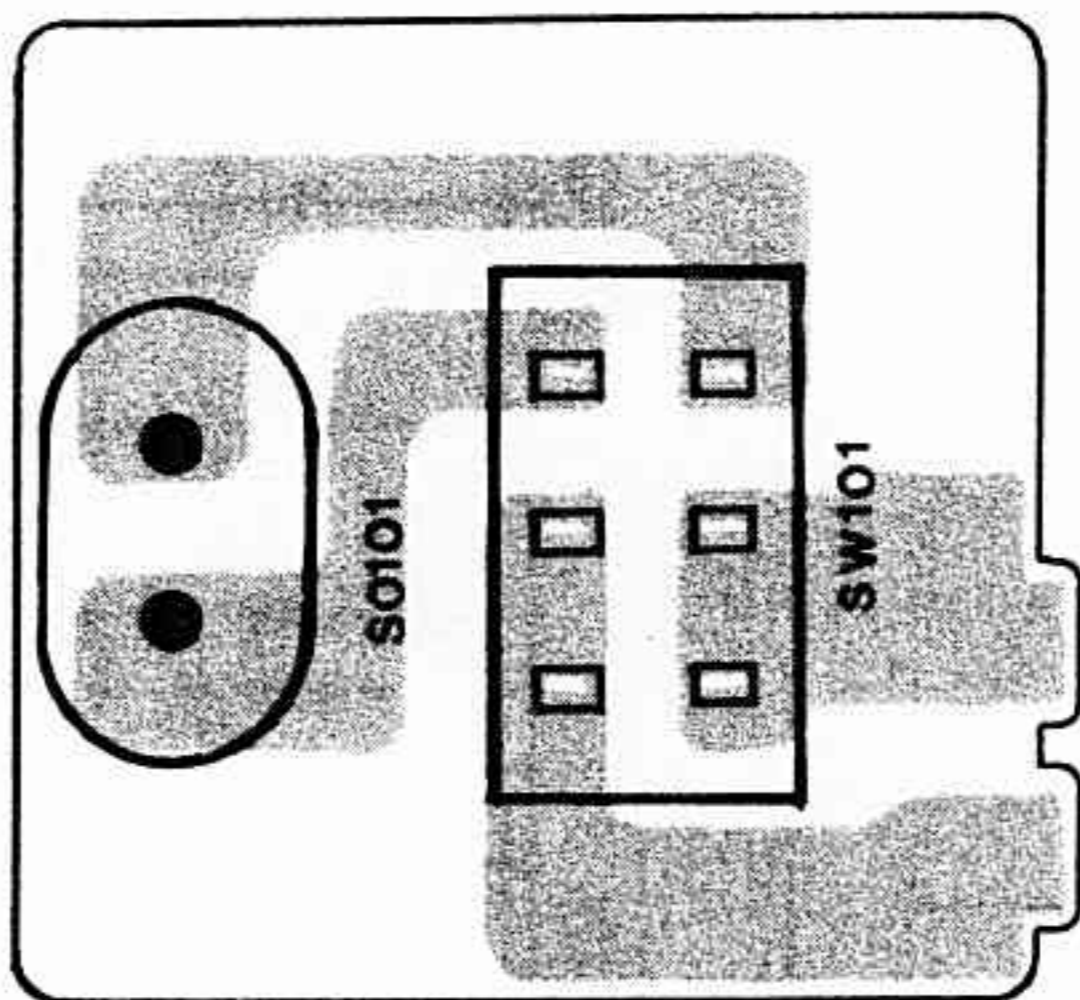

Primary

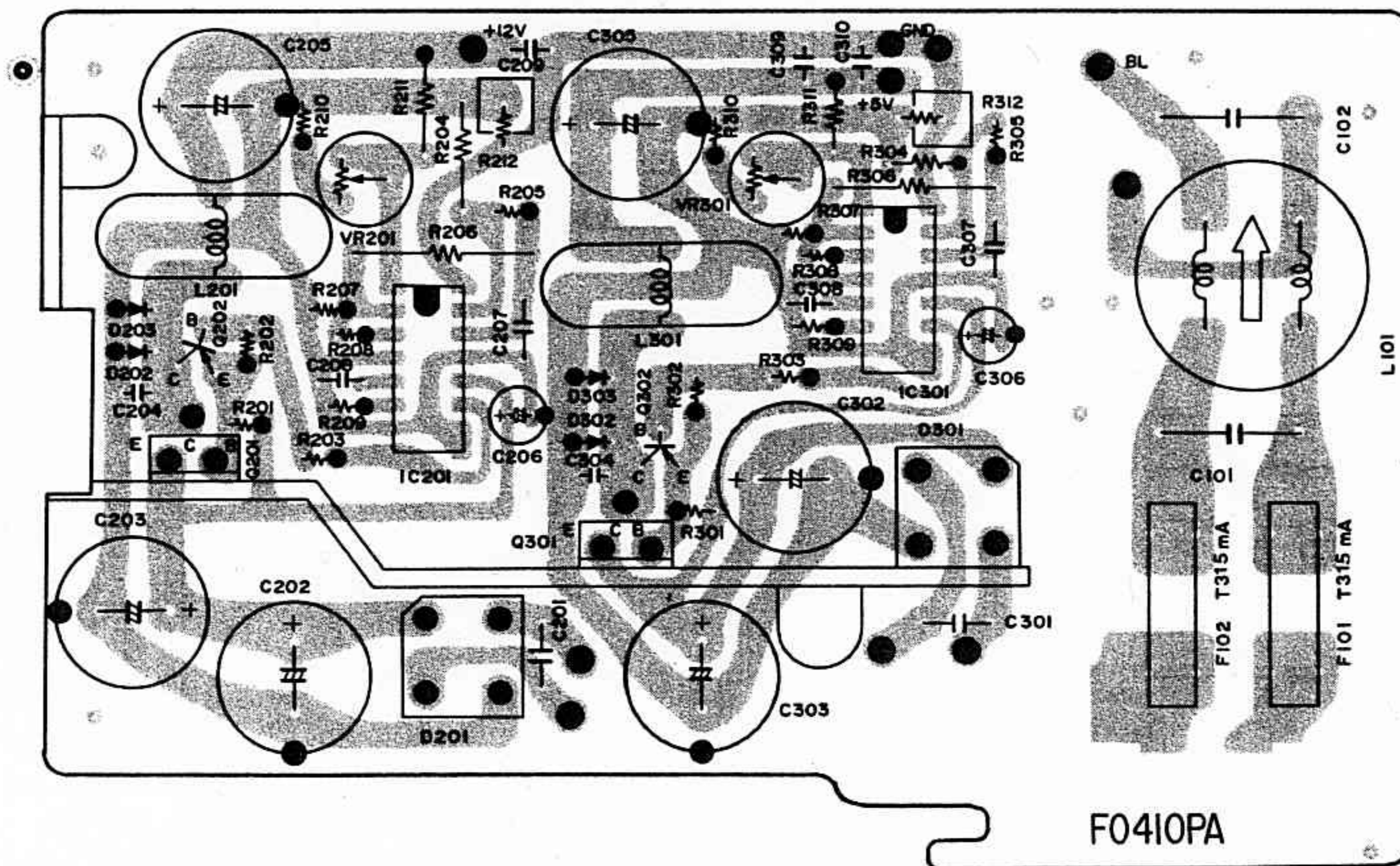

Secondary

■ Disk Drive PWB Circuit (Reference diagram)

1
2
3
4
5
6
7
8
9
10
11

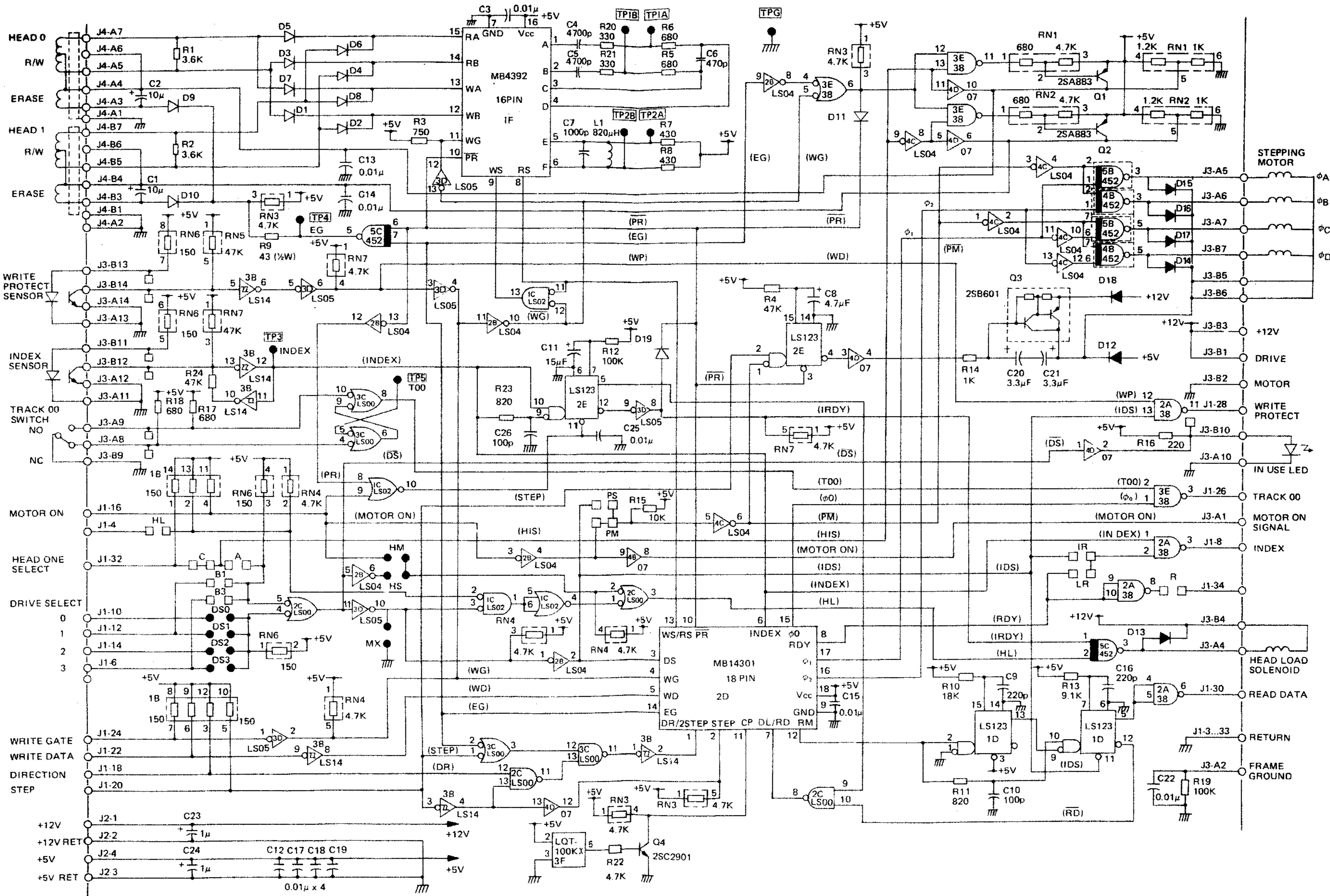

PACKING METHOD

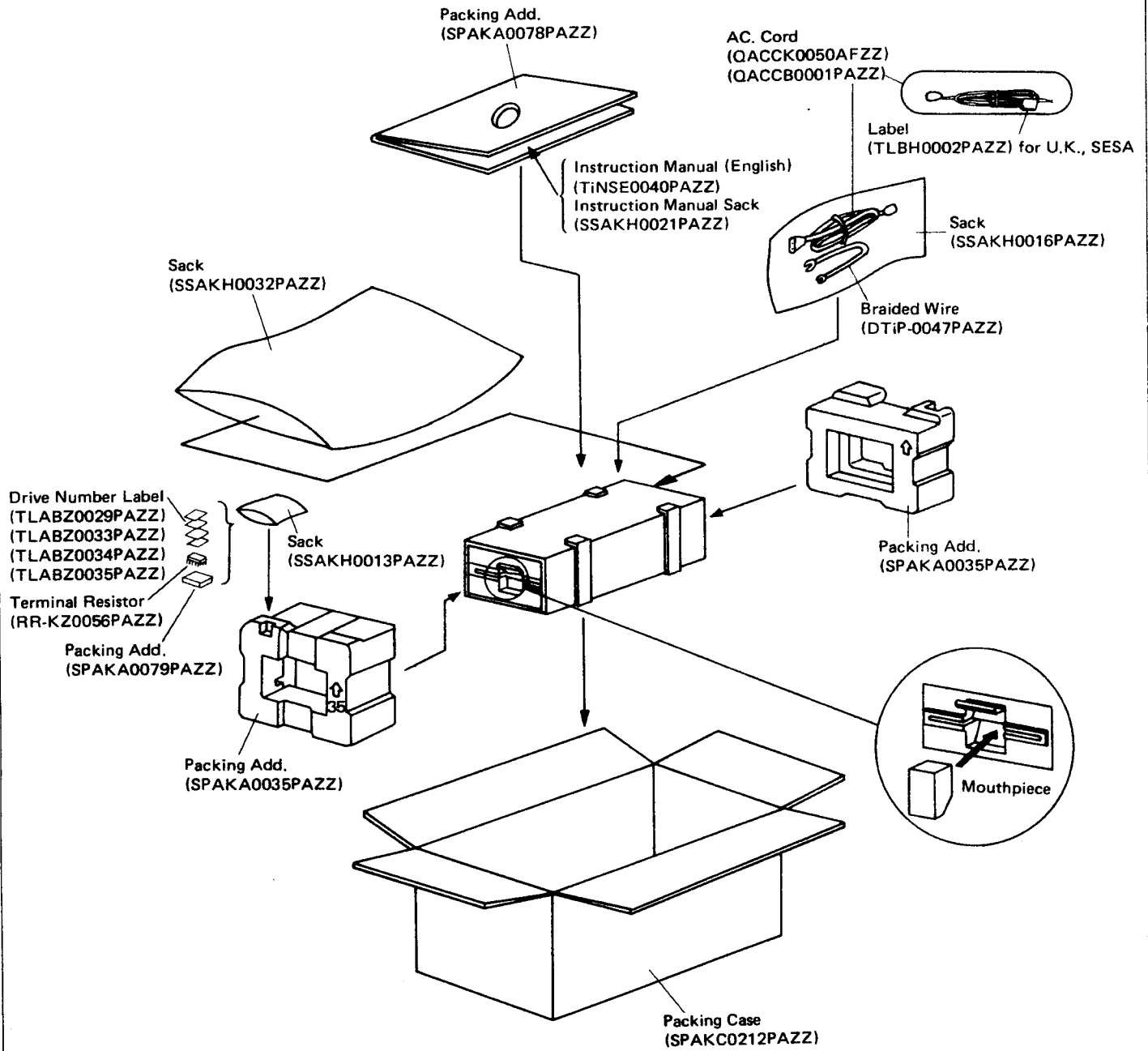

DISASSEMBLED VIEWS

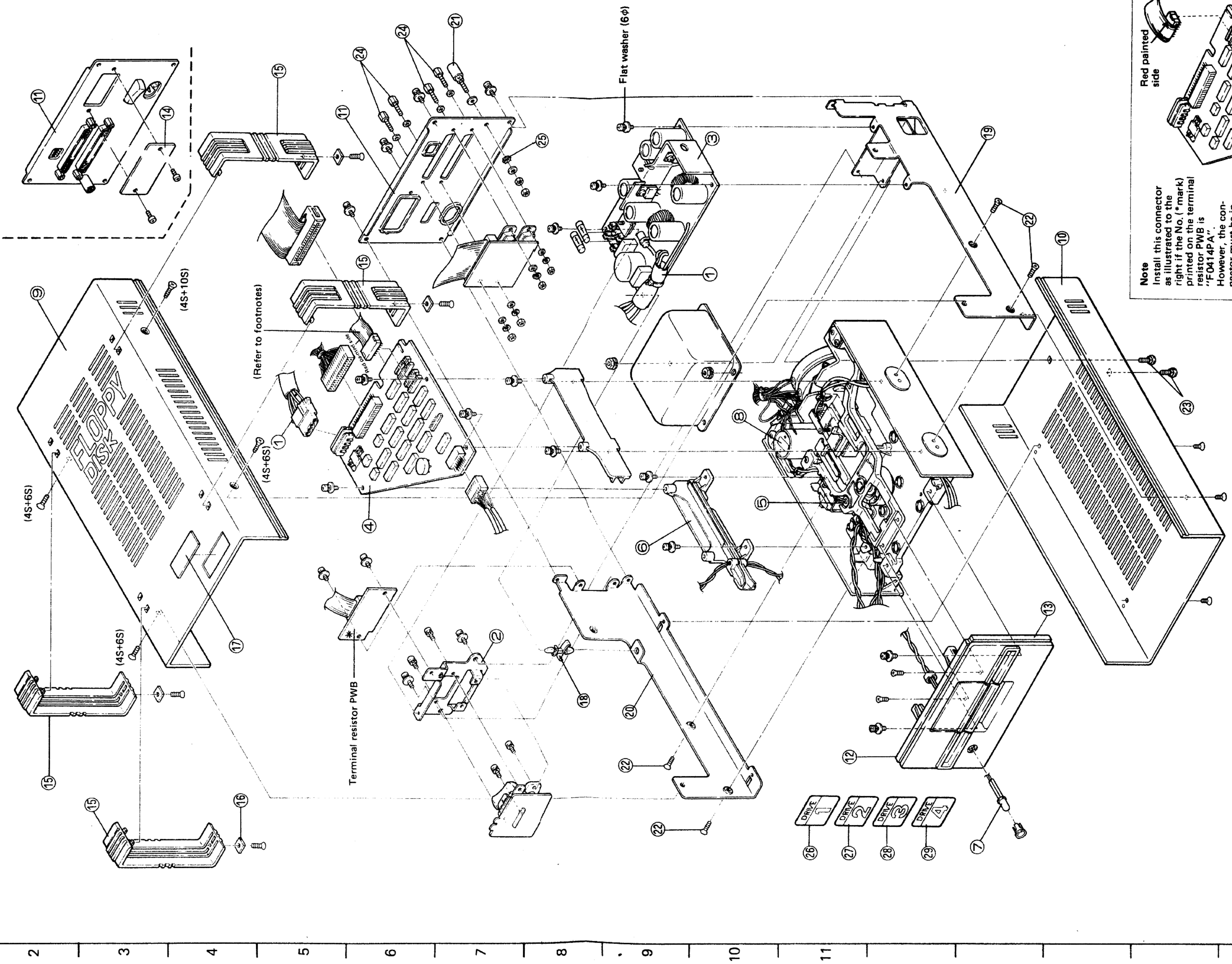

Note
 Install this connector as illustrated to the right if the No. (*mark) printed on the terminal resistor PWB is "F0414PA". However, the connector must be installed as shown above if the PWB No. is "F0414PA01".

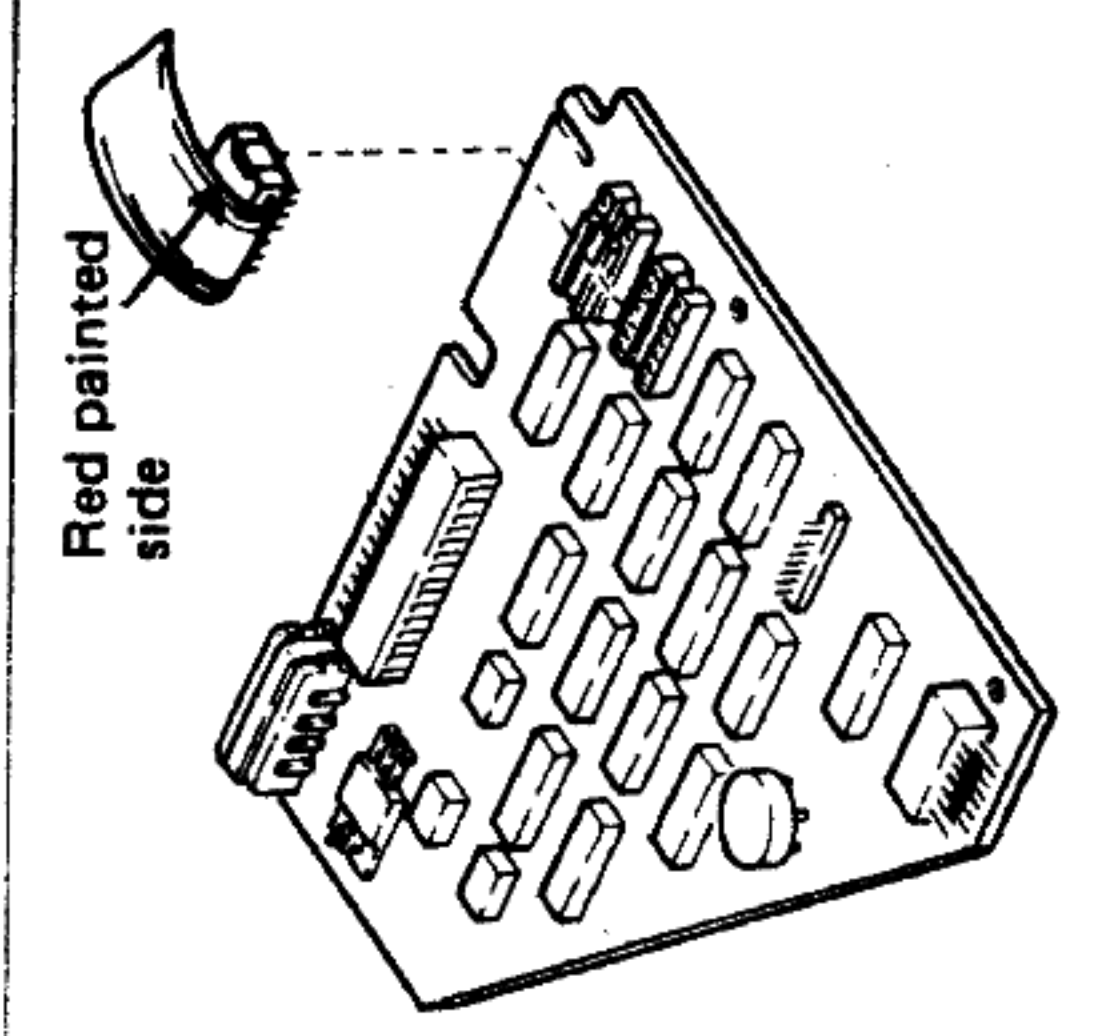

PARTS LIST

REF. NO.	PART NO.	DESCRIPTION	CODE	REF. NO.	PART NO.	DESCRIPTION	CODE
CN2 } CN3 } SW1	QPLGZ0115PAZZ QSW-D0002PAZZ	37-Pin Socket Din-Switch (4 contacts)	BB AQ	*** OTHER SECTION ***			
* TERMINAL RESISTOR PWB UNIT SECTION *				9	GCABA3500PASA	Cabinet A (upper)	BF
	DPWB-0318PAZZ	Assembled Terminal Resistor PWB unit (Not replacement item)	—	10	GCABB3500PASA	Cabinet B (bottom)	BF
MISCELLANEOUS				11	GCABC3500PASA	Cabinet C (rear)	AN
CN1	DSÖCN0167PAZZ	14-Pin Connector with Flat Cable	AW	12	GCÖVA0002PAZZ	Cushion	AE
	QSÖCZ0019PAZZ	14-Pin IC Socket	AF	13	GCÖVA0003PAZZ	Cushion	AB
	RR-KZ0056PAZZ	Terminal Resistor	AE	14	GCÖVA0016PASA	Terminal Resistor Cover	AC
*** DISK DRIVE UNIT SECTION ***				15	GLEGP0003PAZZ	Foot	AG
	95AF141336-01	Belt	BA	16	GLEGP0004PASA	Rubber Foot	AB
4	95AF120138-14	PWB Unit Ass'y /	**	17	HBDGD0002PAZZ	Badge	AN
5	95AF140630-01	Index Lamp Ass'y	BL	18	LHLDF0023PAZZ	PWB Holder	AA
6	95AF120151-01	Medium Guide L Ass'y (with Write Protect Sensor, Lamp)	BN	19	LANGF0068PAZZ	Frame (Right)	AG
7	95AF140640-01	Operation Indicator	AZ	20	LANGF0069PAZZ	Frame (Left)	AG
8	95AF130246-01	Drive Motor Ass'y (with Motor Control PWB)	BY	21	QTANN0003PAZZ	Frame Ground Terminal	AK
				22	LX-BZ0068PAFN	Screw, Drive Fixing Screw	AH
				23	LX-BZ0086PASA	Screw, Round-head Flat-foot Screw	AC
				24	LX-BZ0075PAZZ	Screw, Socket Fixing Screw	AG
				25	LX-WZ0003VAFE	Washer for FG Terminal	AA
			△		QACCK0050AFZZ	AC, Cord (for SEEG)	AQ
			△		QACCB0001PAZZ	AC, Cord (for SUK, SESA)	AQ
			△		TLABH0002PAZZ	AC, Cord Label (for SUK, SESA)	AC
			△		TSPCE0032PAZZ	Specification Panel (for 220V)	AE
			△		TSPCE0031PAZZ	Specification Panel (for 240V)	AE
					TiNSE0040PAZZ	Instruction Manual (English)	AR
					DTiP-0047PAZZ	Braided Wire	AN
				26	TLABZ0029PAZZ	Drive Number Label DRIVE 1	AB
				27	TLABZ0033PAZZ	Drive Number Label DRIVE 2	AB
				28	TLABZ0034PAZZ	Drive Number Label DRIVE 3	AB
				29	TLABZ0035PAZZ	Drive Number Label DRIVE 4	AB