



COMMODORE SEMICONDUCTOR GROUP

a division of Commodore Business Machines, Inc.

950 Rittenhouse Rd., Norristown, PA 19403 • Tel.: 215/666-7950 • TWX: 510/660-4168

HMOS

2332 STATIC READ ONLY MEMORY (4096x8)

DESCRIPTION

The 2332 high performance read only memory is organized 4096 words by 8 bits with a wide range of access times. This ROM is designed to be compatible with all microprocessor and similar applications where high performance, large bit storage and simple interfacing are important design considerations. This device offers TTL input and output levels.

The 2332 operates totally asynchronously. No clock input is required. The two programmable chip select inputs allow four 32K ROMs to be OR-tied without external decoding.

Designed to replace two 2716 16K EPROMS, the 2332 can eliminate the need to redesign printed circuit boards for volume mask programmed ROMS after prototyping with EPROMS.

- 4096 x 8 Bit Organization
- Single +5 Volt Supply
- Access Time — 2332 450 ns
 - 2332A 300 ns
 - 2332B 200 ns
- Completely TTL Compatible
- Totally Static Operation
- Three-State Outputs for Wire-OR Expansion
- Two Programmable Chip Selects
- Pin Compatible with 2716 & 2732 EPROM
- Replacement for Two 2716s
- 2708/2716 EPROMS Accepted as Program Data Inputs
- 400mV Noise Immunity on Inputs

ORDERING INFORMATION

MXS 2332

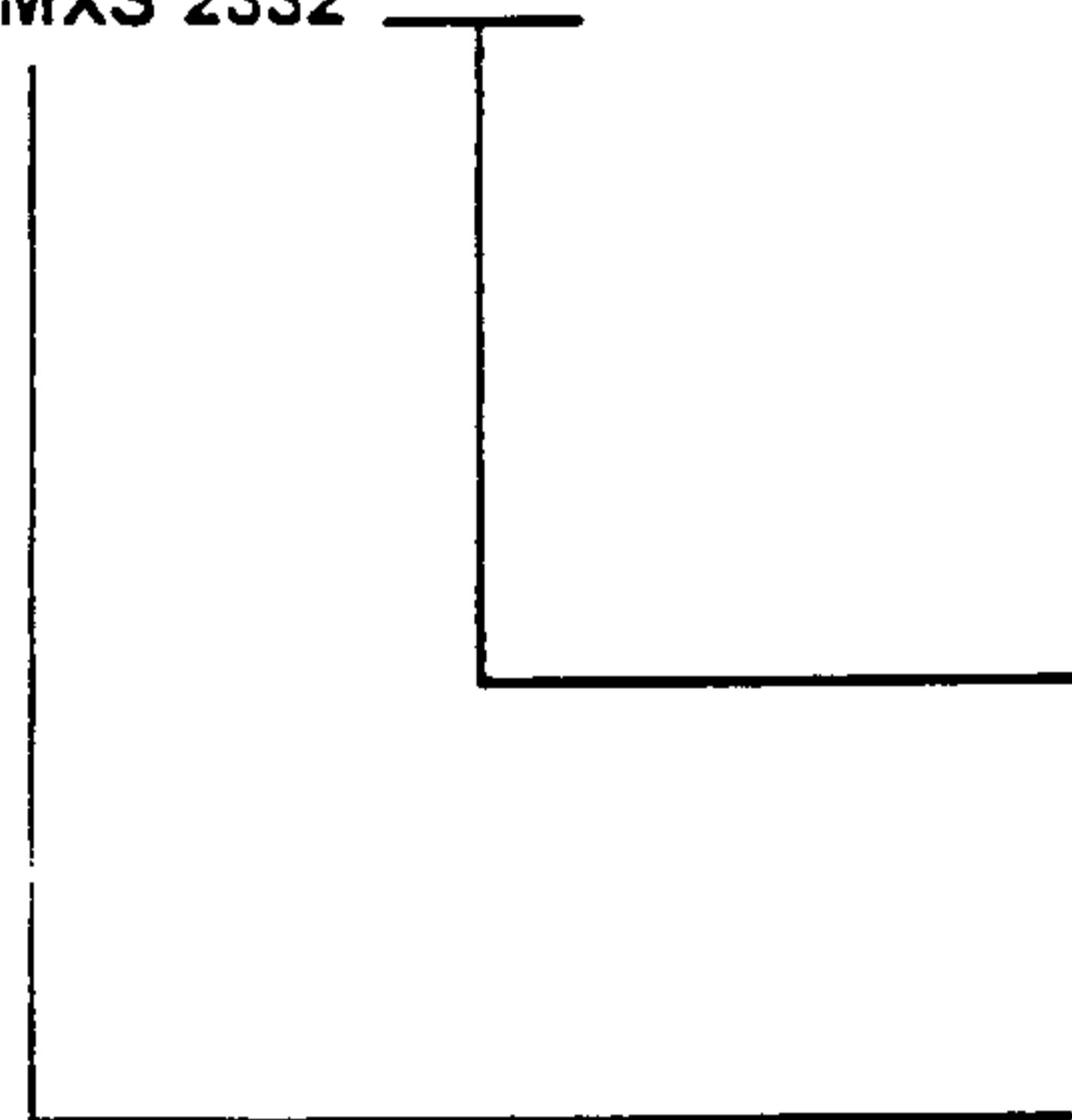

FREQUENCY RANGE
 NO SUFFIX = 450 ns
 A = 300 ns
 B = 200 ns

PACKAGE DESIGNATOR
 C = CERAMIC
 P = PLASTIC

PIN CONFIGURATION

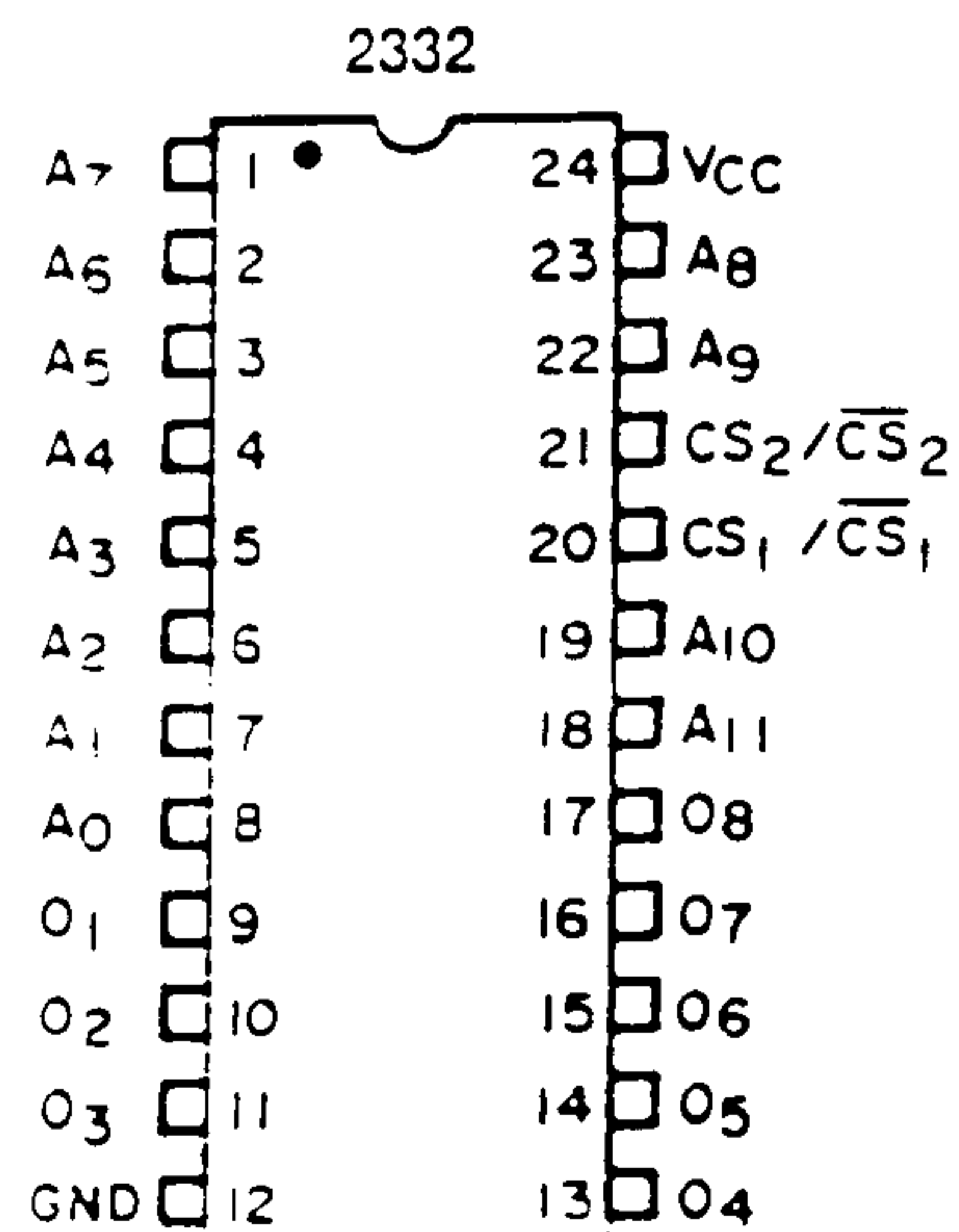

2332 STATIC READ ONLY MEMORY (4096x8)

ABSOLUTE MAXIMUM RATINGS

Ambient Operating Temperature	0° to +70 °C
Storage Temperature	-65 °C to +150 °C
Supply Voltage to Ground Potential	-0.5V to +7.0V
Applied Output Voltage	-0.5V to +7.0V
Applied Input Voltage	-0.5V to +7.0V
Power Dissipation	1.0W

COMMENT

Stresses above those listed under "Absolute Maximum Ratings" may cause permanent damage to the device. This is a stress rating only and functional operation of the device at these or any other conditions above those indicated in the operational sections of this specification is not implied.

D.C. CHARACTERISTICS

$T_A = 0^\circ\text{C}$ to $+70^\circ\text{C}$, $V_{CC} = 5.0\text{V} \pm 5\%$ (unless otherwise specified)

Symbol	Parameter	Min.	Max.	Units	Test Conditions
I _{CC1}	Power Supply Current		100	mA	$V_{IN} = V_{CC}$, $V_O = \text{Open}$, $T_A = 0^\circ\text{C}$
I _{CC2}	Power Supply Current		95	mA	$V_{IN} = V_{CC}$, $V_O = \text{Open}$, $T_A = 25^\circ\text{C}$
I _O	Output Leakage Current		10	uA	Chip Deselected, $V_O = 0$ to V_{CC}
I _I	Input Load Current		10	uA	$V_{CC} = \text{Max.}$ $V_{IN} = 0$ to V_{CC}
V _{OL}	Output Low Voltage		0.4	Volts	$V_{CC} = \text{Min.}$ $I_{OL} = 2.1\text{mA}$
V _{OH}	Output High Voltage	2.4		Volts	$V_{CC} = \text{Min.}$ $I_{OH} = -400\text{uA}$
V _{IL}	Input Low Voltage	-0.5	0.8	Volts	See note 1
V _{IH}	Input High Voltage	2.0	$V_{CC} + 1$	Volts	

A.C. CHARACTERISTICS

$T_A = 0^\circ\text{C}$ to $+70^\circ\text{C}$, $V_{CC} = 5.0\text{V} \pm 5\%$ (unless otherwise specified)

Symbol	Parameter	2332		2332A		2332B		Units	Test Condition
		Min.	Max.	Min.	Max.	Min.	Max.		
T _{ACC}	Address Access Time	—	450	—	300	—	200	ns	See Note 2
T _{CO}	Chip Select Access Time	—	200	—	100	—	75	ns	
T _{DF}	Chip Deselect Delay		175		75		75	ns	
T _{OH}	Previous Data Valid After Add Change	40	—	40	—	40	—	ns	

CAPACITANCE $T_A = 25^\circ\text{C}$, $f = 1.0\text{MHz}$, See Note 3

Symbol	Parameter	Min.	Max.	Units	Test Conditions
C _{IN}	Input Capacitance		8	pF	All Pins except Pin under
C _{OUT}	Output Capacitance		10	pF	Test Tied to AC Ground

Note 1: Input levels that swing more negative than -0.5V will be clamped and may cause damage to the device.

Note 2: Loading 1 TTL + 100 pF, input transition time: 20 ns.

Timing measurement levels: input 1.5V, output 0.8V and 2.0V. $C_L = 100$ pF.

Note 3: This parameter is periodically sampled and is not 100% tested.

TIMING DIAGRAM

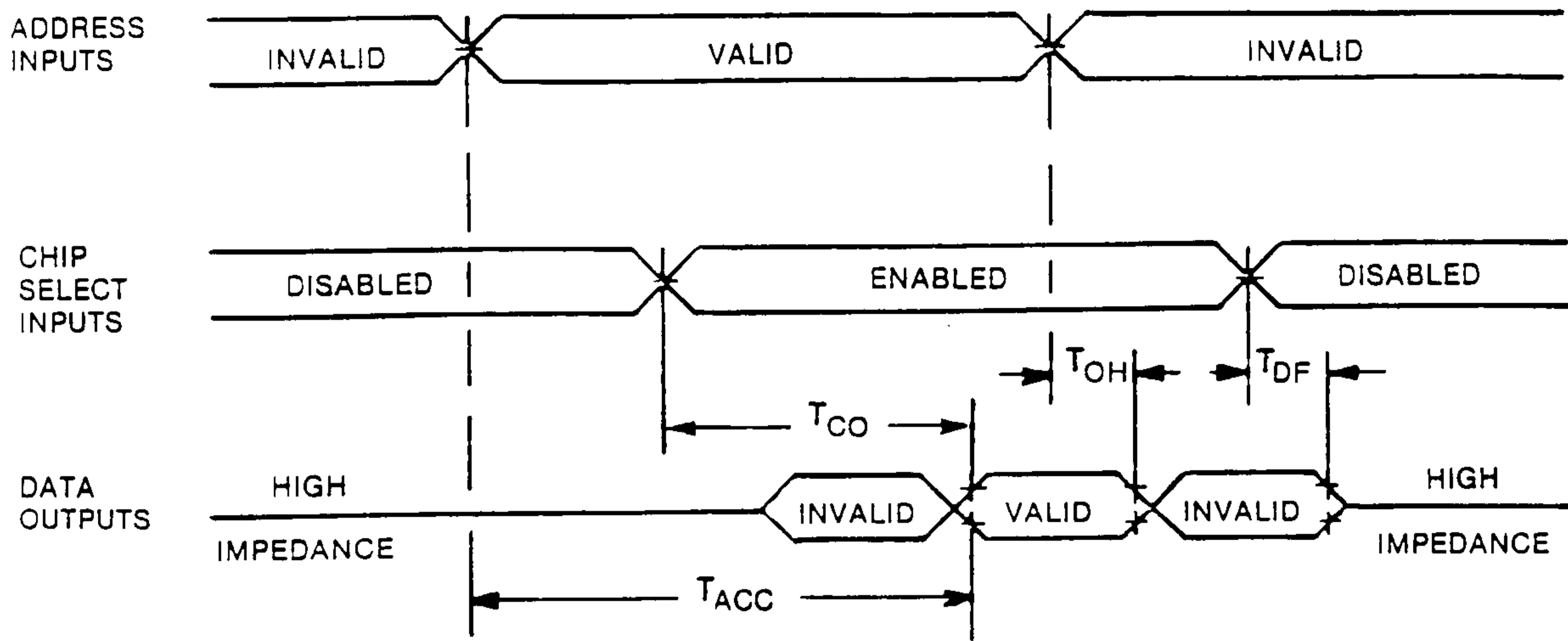

BLOCK DIAGRAM

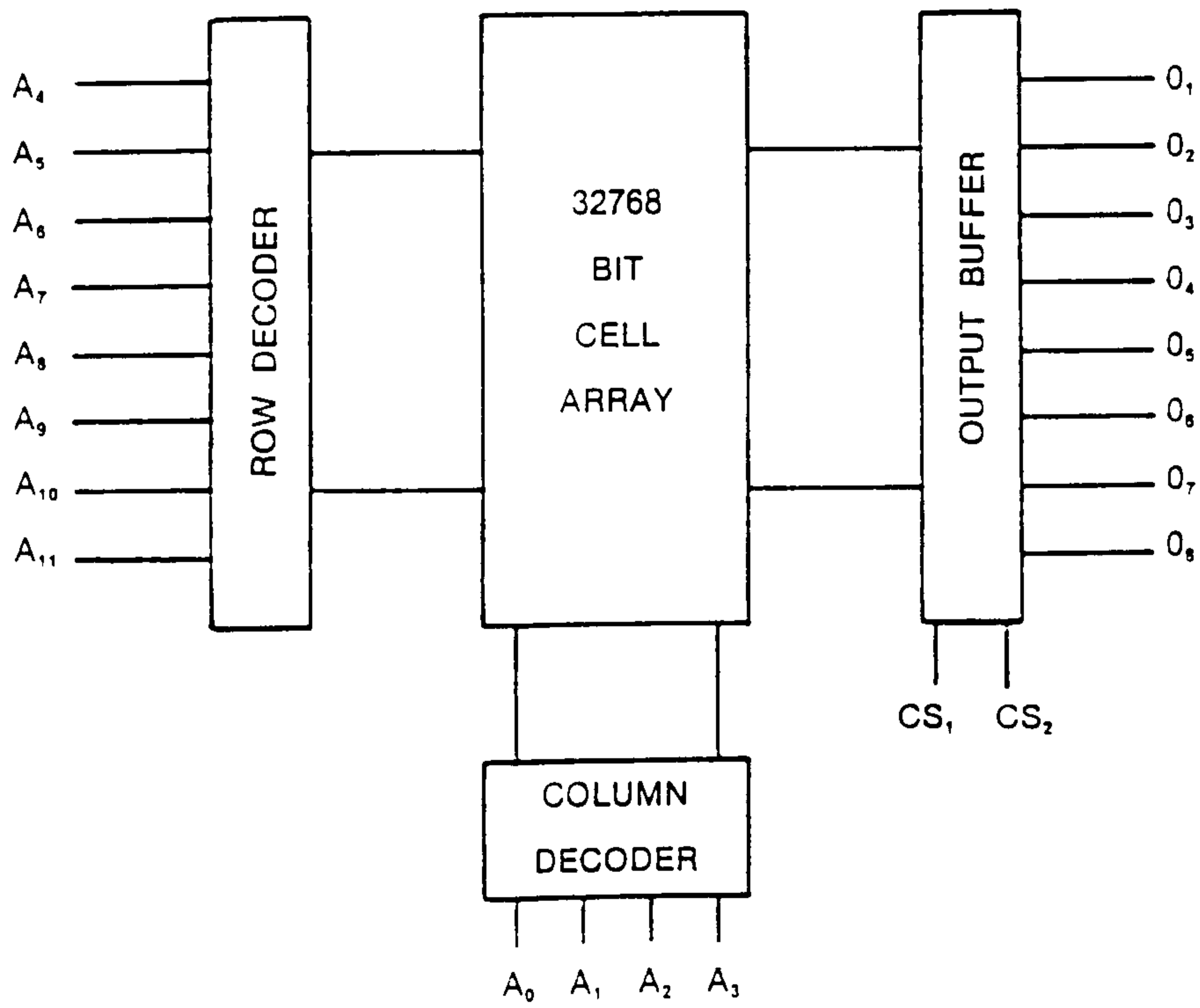

TYPICAL CHARACTERISTICS

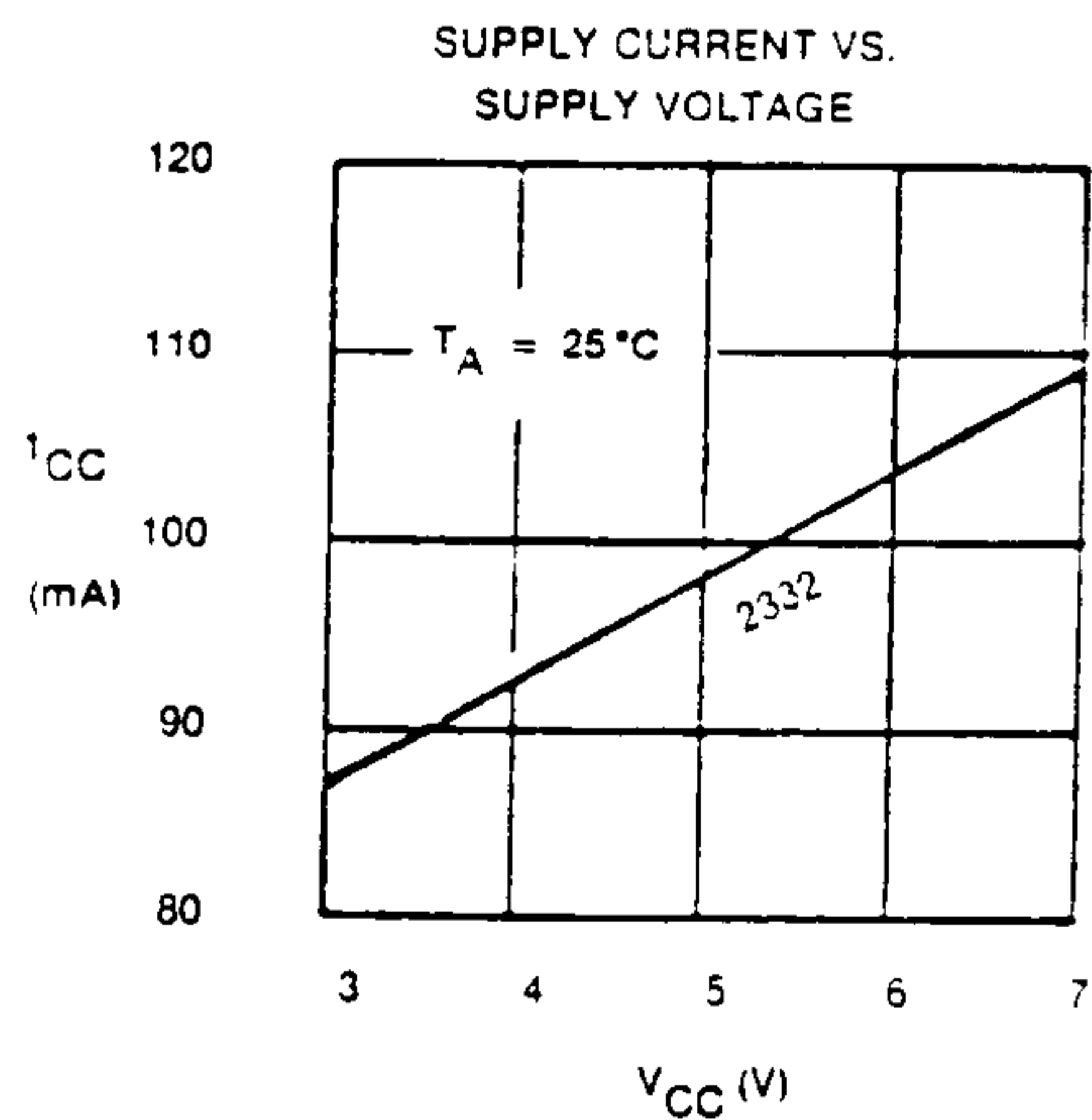
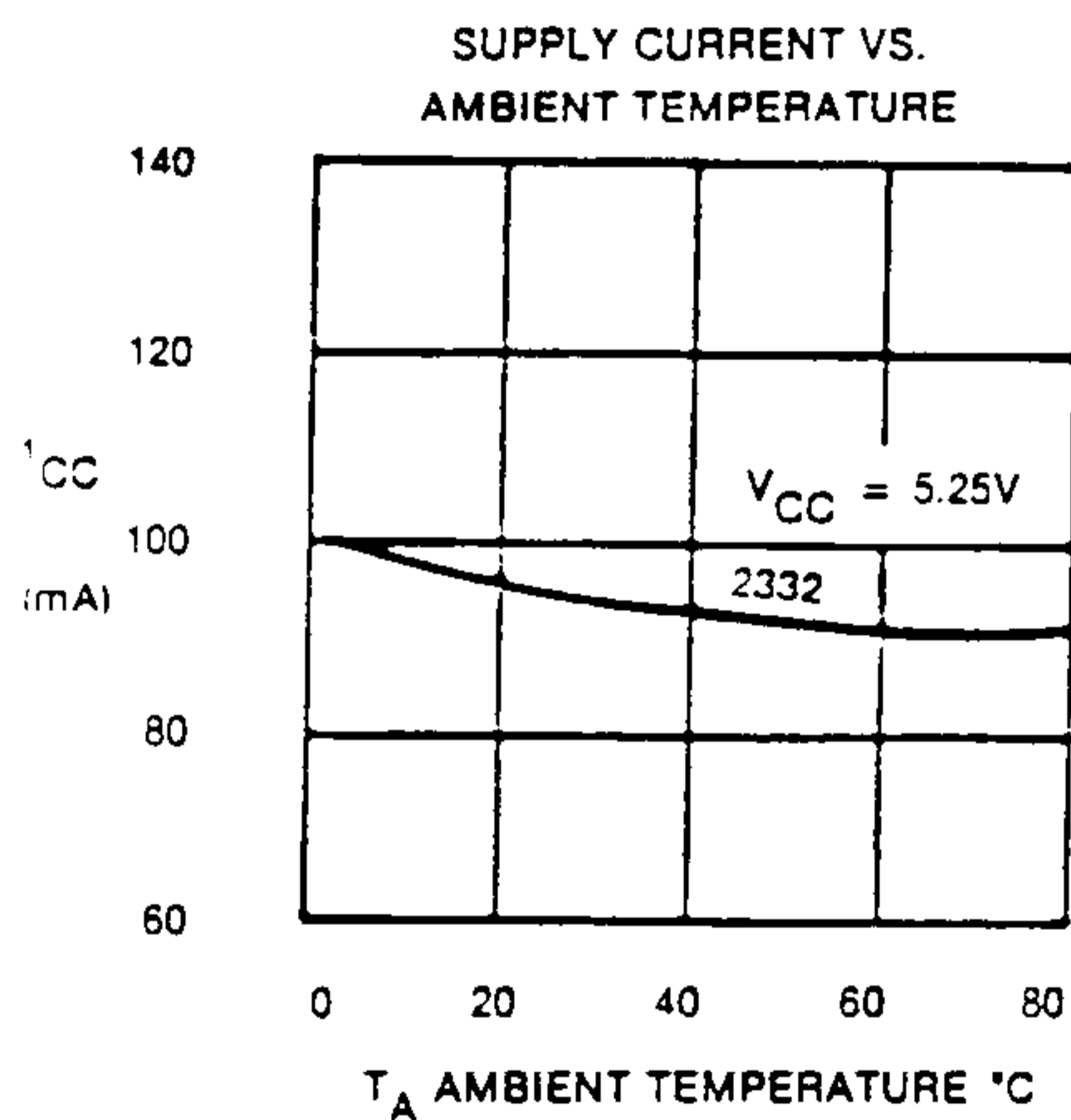
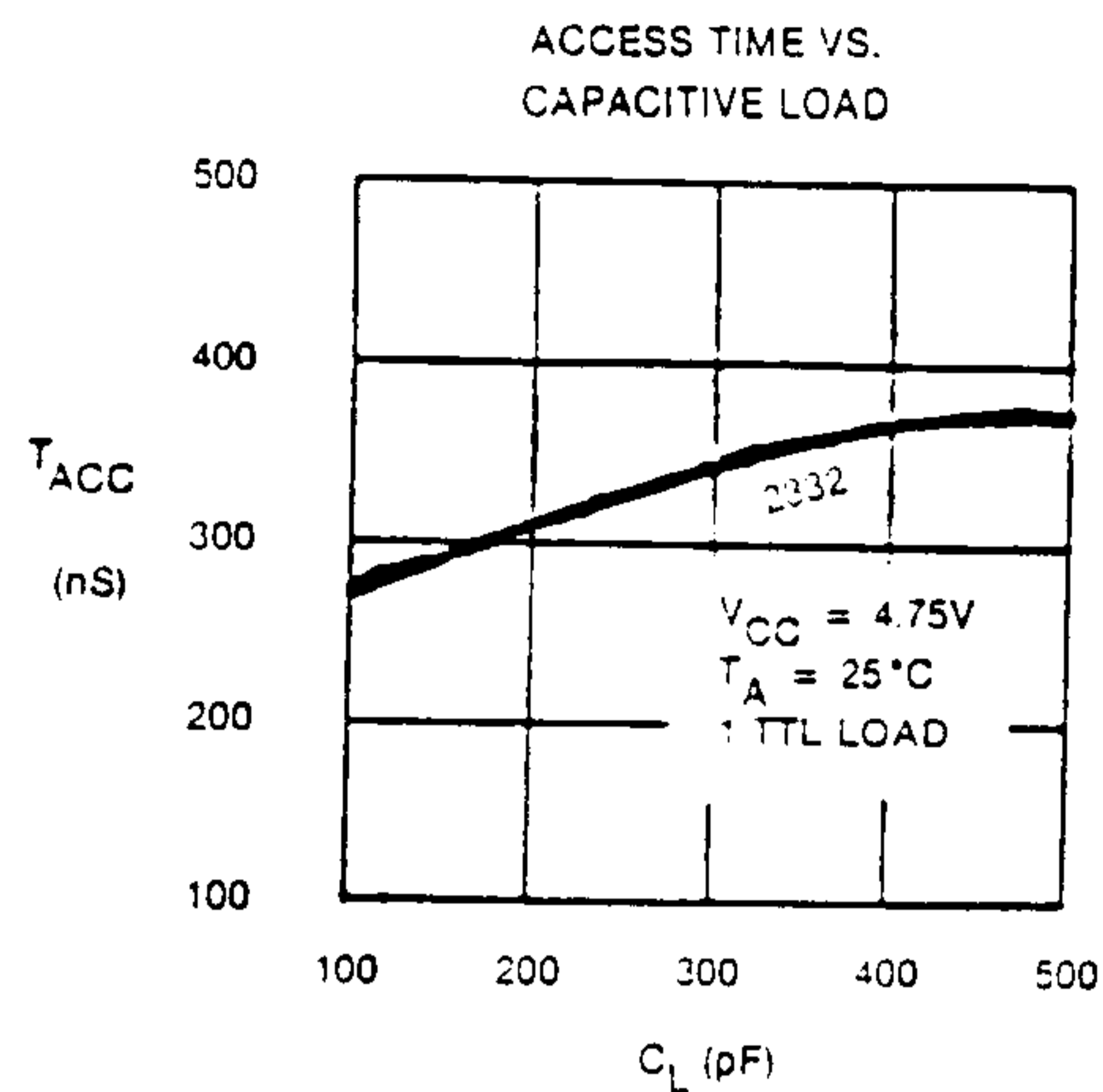
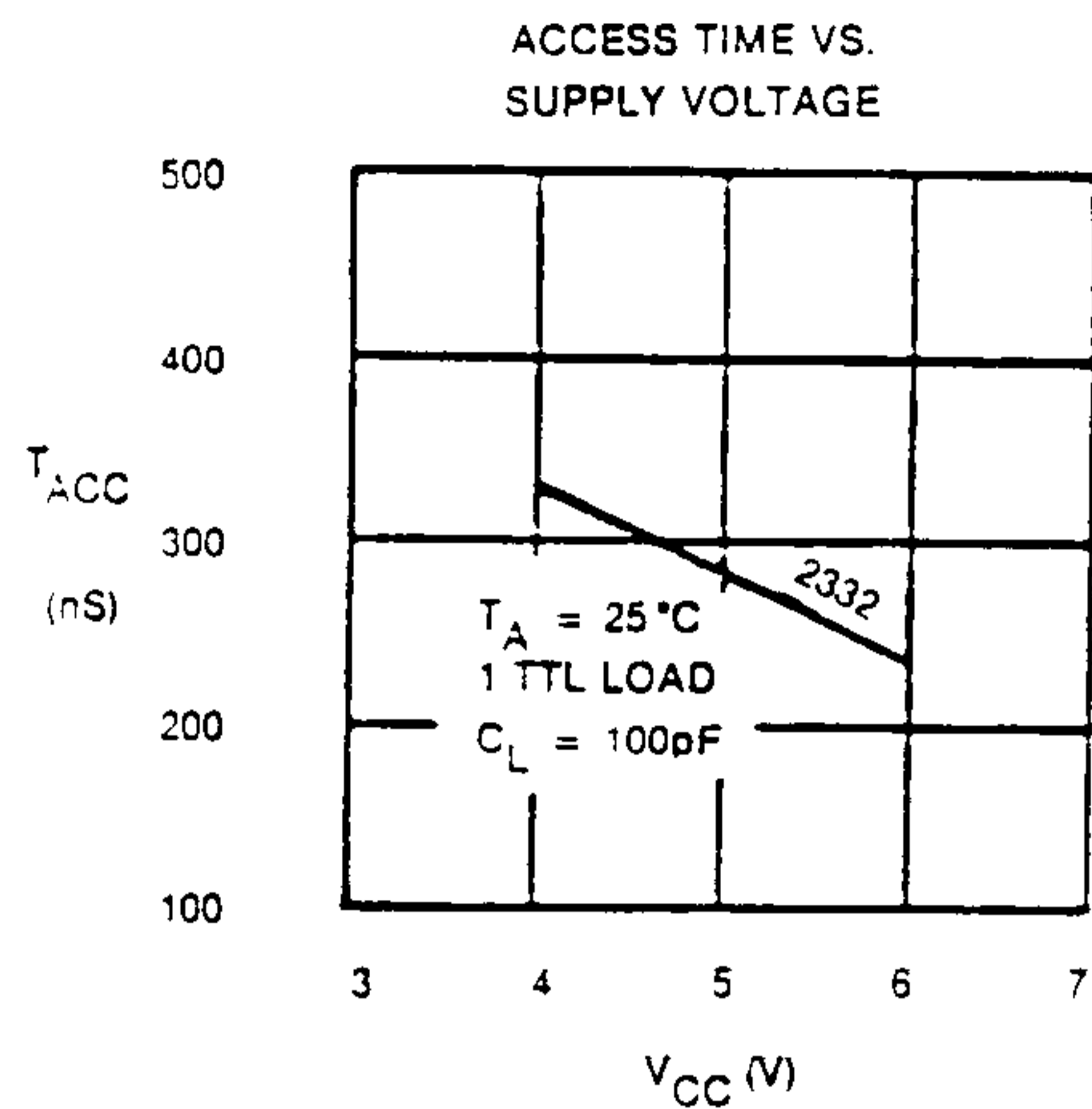

COMMODORE SEMICONDUCTOR GROUP reserves the right to make changes to any products herein to improve reliability, function or design. COMMODORE SEMICONDUCTOR GROUP does not assume any liability arising out of the application or use of any product or circuit described herein; neither does it convey any license under its patent rights nor the rights of others.