

SHARP

Joy Stick

MODEL **MZ-1X03**

INSTRUCTION MANUAL



FOREWORD

Congratulations on your purchase of Sharp's Joy Stick [MZ-1X03]. Be sure to read this instruction manual in order to use the Joy Stick properly. Be sure to keep this instruction manual. If during use there should be something that you do not understand or something is not functioning properly, it should prove useful.

CONTENTS

- HOW TO CONNECT 1
- FUNCTIONS RELATED TO THE JOY STICK 2
- PROGRAM EXAMPLES 4
- HOW TO USE AT THE MACHINE LANGUAGE LEVEL 7
- JOY STICK CIRCUIT DIAGRAM 14

HOW TO CONNECT

- (1) Check to be sure that power to the MZ-700 series unit as well as to the peripheral equipment are all OFF.**
- (2) Remove the cover on the Joy Stick connector located on the left side of the rear panel of the MZ-700 unit (refer to page 104 "3.1 Appearance of the MZ-700 Series Personal Computers" in the OWNER'S MANUAL).
(Save the cover, and attach again when disconnecting the cable.)**
- (3) With the projection facing up, connect the cable to either the left or right connector. If both connectors are connected, 2 Joy Sticks can be used simultaneously.**

*** In the instructions below, the Joy Stick connected to the connector on the left (while facing the rear panel) is called stick 1 and the one connected to the connector on the right is called stick 2.**

FUNCTIONS RELATED TO THE JOY STICK

The function JOY is completely defined in the BASIC for the MZ-700 series.

Format : JOY (n)

n: integer from 0 to 7

Example: M=JOY (I)

N=JOY (B)

Function: Inputs data from the Joy Stick

There are 2 types of input data.

(1) For argument n, 0-3

Stick position

0: value of the X-axis of stick 1

1: value of the Y-axis of stick 1

2: value of the X-axis of stick 2

3: value of the Y-axis of stick 2

Value of function JOY (n) ranges 0-255

(2) For argument n, 4–7

State of the pushbutton switch

4: state of SW1 of stick 1

5: state of SW2 of stick 1

6: state of SW1 of stick 2

7: state of SW2 of stick 2

Values of function JOY (n)

0: switch is in OFF state

–1: switch is in ON state

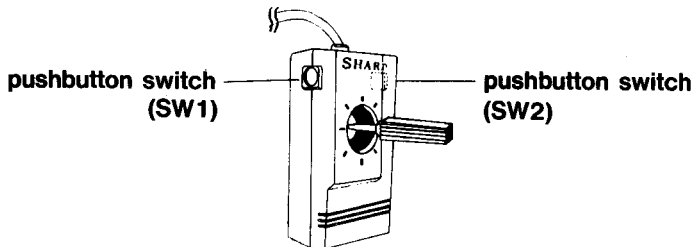

PROGRAM EXAMPLES

[Program A]

A program which moves the character "♥" in the direction the Joy Stick is moved. (One space is left opened on the right edge of the screen.)

Note: This is an example for stick 1.

To use this example for stick 2, change the argument of the JOY function in lines 20 and 30. (0 to 2, 1 to 3)

```
10 PRINT "0"  
20 X=INT(JOY(0)/6.5)  
30 Y=INT(JOY(1)/10.6)  
40 IF X=39 THEN X=38  
50 CURSOR X,Y  
60 PRINT " ♥";  
70 FOR A=0 TO 20:NEXT  
80 CURSOR X,Y  
90 PRINT " ";  
100 GOTO 20
```

[Program B]

This is a program which takes the input from the Joy Stick to correspond to a semi-graphic display on the screen.

If SW1 or SW2 is pressed, the color of the dot changes in sequence from 1 to 7. To use this example for stick 2 (connected to the right connector), change B=0 in line 10 to B=2.

```
10 B=0:C=1:F=1:COLOR ,,7,0:PRINT "0"  
20 JX=INT(JOY(B)/3.2)  
30 JY=INT(JOY(B+1)/5.2)  
40 SET JX,JY,C  
50 CURSOR 2,2:PRINT JX,JY,C,  
60 IF(JOY(B+4))+(JOY(B+5)) GOTO 80  
70 F=0:GOTO20  
80 IF F=0 GOSUB 100  
90 GOTO20  
100 F=1:C=C+1:IF C=8 THEN C=0  
110 RETURN
```

[Program C]

This is a program which takes the input from the Joy Stick to correspond to a semi-graphic display on the screen. If SW1 is pressed, the color of the dot changes in sequence from 1 to 7. If SW2 is pressed, the set and reset mode of the dot changes. If SW2 is pressed while SW1 is being pressed, and then if SW1 is released, the screen clears. To use this example for stick 2 (connected to the right connector), change B=0 in line 10 to B=2.

```
10 B=0:C=1:F=1:COLOR ,,7,0:PRINT "■"  
20 JX=INT(JOY(B)/3.2)  
30 JY=INT(JOY(B+1)/5.2)  
40 SET JX,JY,C  
50 CURSOR 2,2:PRINT JX,JY,F,  
60 IF JOY(B+4) GOSUB 100  
70 IF JOY(B+5) GOSUB 130  
80 IF F THEN RESET JX,JY  
90 GOTO 20  
100 W=B+4:GOSUB 150:IF JOY(B+5) THEN PRINT "■":GOTO 140  
110 C=C+1:W=B+4:IF C=8 THEN C=0  
120 GOTO 150  
130 F=(F=0)  
140 W=B+5  
150 IF JOY(W) THEN 150  
160 RETURN
```

HOW TO USE AT THE MACHINE LANGUAGE LEVEL

A machine language program example is given which reads the state of the Joy Stick. The program given here reads the position of sticks 1 and 2, as well as the state of SW1 and SW2. The program is given as a subroutine.

[Switch Read Routine]

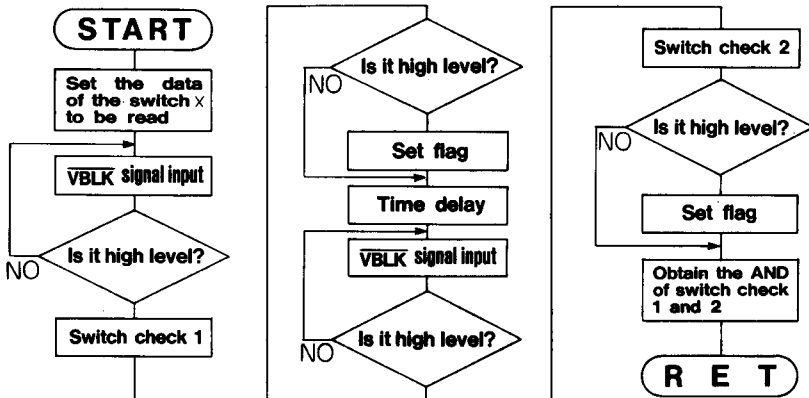

[Stick Read Routine]

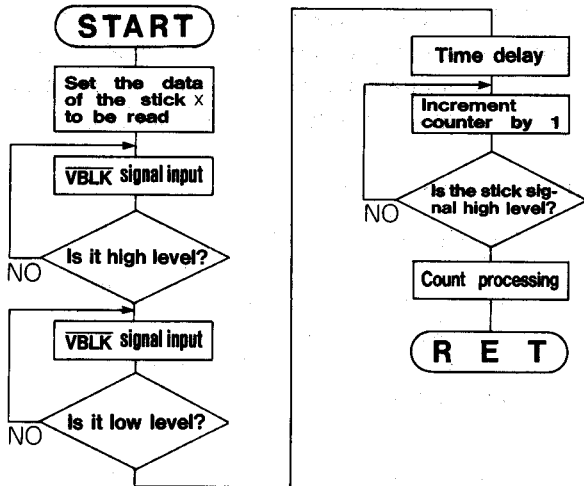

It is assumed that this program will be used as a subroutine. The result is returned to register A. If the switch is pressed, the subroutine returns a value other than 0 to the A register.

Note: This program can be used in the address range of 0000 to CFFF. It can be used beyond D000 only in the V-RAM mode.

```

01 0000      ;
02 0000      ; STICK-CONTROL
03 0000      ;
04 E002 P    PORTC: EQU    E002H
05 0008 P    PORTJ: EQU    08H
06 0000      ;
07 0000      ; CALL JA1 = STICK1 X
08 0000      ; CALL JA2 = STICK1 Y
09 0000      ;
10 0000      ; CALL JB1 = STICK2 X
11 0000      ; CALL JB2 = STICK2 Y
12 0000      ;
13 0000      ; ANSWER = Acc A REGISTER
14 0000      ;
15 0000      JA1:   ENT
16 0000 3E4E      LD     A,4EH      ; BIT 1,(HL)
17 0002 180A      JR     LPO
18 0004          ;
19 0004          JA2:   ENT
20 0004 3E56      LD     A,56H      ; BIT 2,(HL)
21 0006 1806      JR     LPO
22 0008          ;
23 0008          JB1:   ENT
24 0008 3E5E      LD     A,5EH      ; BIT 3,(HL)
25 000A 1802      JR     LPO
26 000C          ;
27 000C          JB2:   ENT
28 000C 3E66      LD     A,66H      ; BIT 4,(HL)
29 000E          ;

```

30	000E	F3	LP0:	DI		
31	000F	E5		PUSH	HL	
32	0010	D5		PUSH	DE	
33	0011	322D00		LD	(LP4+2),A	; OPERAND SET
34	0014	11FFFF		LD	DE,FFFFH	
35	0017	2102E0		LD	HL,PORTC	
36	001A	CB7E	LP1:	BIT	7,(HL)	; WAIT V-BLANK HIGH
37	001C	CA1A00		JP	Z,LP1	
38	001F	CB7E	LP2:	BIT	7,(HL)	; WAIT V-BLANK LOW
39	0021	C21F00		JP	NZ,LP2	
40	0024	2E08		LD	L,PORTJ	
41	0026	3E11		LD	A,11H	
42	002B	3D	LP3:	DEC	A	; TIME DELAY
43	0029	20FD		JR	NZ,LP3	
44	002B	13	LP4:	INC	DE	; COUNTER ADD TO ONE
45	002C	CB46		BIT	0,(HL)	; LEVEL CHECK
46	002E	CA2B00		JP	Z,LP4	; NEXT COUNT
47	0031	7A		LD	A,D	; OVER COUNT CHECK
48	0032	E7		OR	A	
49	0033	7B		LD	A,E	
50	0034	D1		POP	DE	
51	0035	E1		POP	HL	
52	0036	FB		EI		
53	0037	C8		RET	Z	
54	003B	3EFF		LD	A,FFH	; MAX COUNT SET
55	003A	C9		RET		
56	003B			DEFS	5	
57	0040			SKP	H	

```

01 0040      ;
02 0040      ; CONTROL SWITCH
03 0040      ;
04 0040      ;
05 0040      ; CALL SW1 = STICK1 SWICH1
06 0040      ; CALL SW2 = STICK1 SWICH2
07 0040      ;
08 0040      ; CALL SW3 = STICK2 SWICH1
09 0040      ; CALL SW4 = STICK2 SWICH2
10 0040      ;
11 0040      ; ANSWER = Acc A REGISTER
12 0040      ;
13 0040      SW1:   ENT
14 0040 3E4E      LD      A,4EH      ; BIT 1,(HL)
15 0042 180A      JR      LP5
16 0044      ;
17 0044      SW2:   ENT
18 0044 3E56      LD      A,56H      ; BIT 2,(HL)
19 0046 1806      JR      LP5
20 0048      ;
21 0048      SW3:   ENT
22 0048 3E5E      LD      A,5EH      ; BIT 3,(HL)
23 004A 1802      JR      LP5
24 004C      ;
25 004C      SW4:   ENT
26 004C 3E66      LD      A,66H      ; BIT 4,(HL)
27 004E      ;
28 004E F3        LP5:   DI
29 004F 327F00    LD      (LPB+1),A      ; OPERAND SET

```

30	0052	326100		LD	(LF7+1),A	:
31	0055	E5		PUSH	HL	
32	0056	2102E0		LD	HL,E002H	
33	0059	CB7E	LP6:	BIT	7,(HL)	: WAIT V-BLANK HIGH
34	005B	CA5900		JP	Z,LP6	
35	005E	2E08		LD	L,PORTJ	
36	0060	CB46	LP7:	BIT	0,(HL)	: SWITCH CHECK
37	0062	7D		LD	A,L	
38	0063	CA6700		JP	Z,LPB	: PUSH SWITCH 1
39	0066	AF		XOR	A	
40	0067	328700	LP8:	LD	(LPD),A	
41	006A	3E09		LD	A,9	
42	006C	F5	LP9:	PUSH	AF	: WAIT 10.4 ms
43	006D	AF		XOR	A	
44	006E	3D		DEC	A	
45	006F	20FD		JR	NZ,-1	
46	0071	F1		POP	AF	
47	0072	3D		DEC	A	
48	0073	20F7		JR	NZ,LP9	
49	0075	2E02		LD	L,2	
50	0077	CB7E	LPA:	BIT	7,(HL)	
51	0079	CA7700		JP	Z,LPA	
52	007C	2E08		LD	L,PORTJ	
53	007E	CB46	LPB:	BIT	0,(HL)	: SWITCH CHECK 2
54	0080	7D		LD	A,L	
55	0081	CA8500		JP	Z,LPC	: PUSH SWITCH 2
56	0084	AF		XOR	A	
57	0085	6F	LPC:	LD	L,A	
58	0086	3E		DEFB	3EH	
59	0087	00	LPD:	DEFB	00	
60	0088	A5		AND	L	

** Z80 ASSEMBLER ZZ-004C <STICK> PAGE 03

??,??,??

01	0089	E1	POP	HL
02	008A	FB	EI	
03	008B	C9	RET	
04	008C		END	

** Z80 ASSEMBLER ZZ-004C <STICK> PAGE 04

??,??,??

JA1	0000	JA2	0004	JB1	0008	JB2	000C	LP0	000E
LP1	001A	LP2	001F	LP3	002B	LP4	002B	LP5	004E
LP6	0059	LP7	0060	LP8	0067	LP9	006C	LPA	0077
LPB	007E	LPC	0085	LPD	0087	PDRTC	E002	PDR TJ	0008
SW1	0040	SW2	0044	SW3	0048	SW4	004C		

JOY STICK CIRCUIT DIAGRAM

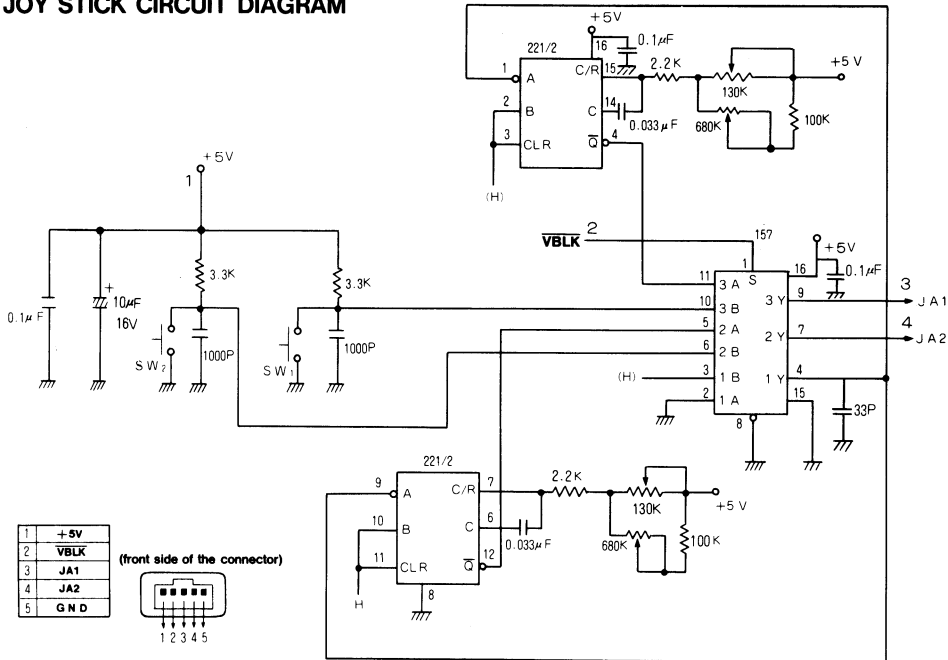

*

*

*

MEMO

*

*

*

*

*

*

MEMO

*

*

*

*

*

*

MEMO

*

*

*

SHARP CORPORATION

OSAKA, JAPAN

Printed in Japan