

SHARP SERVICE MANUAL

CODE: 00ZMZ-1D05///E

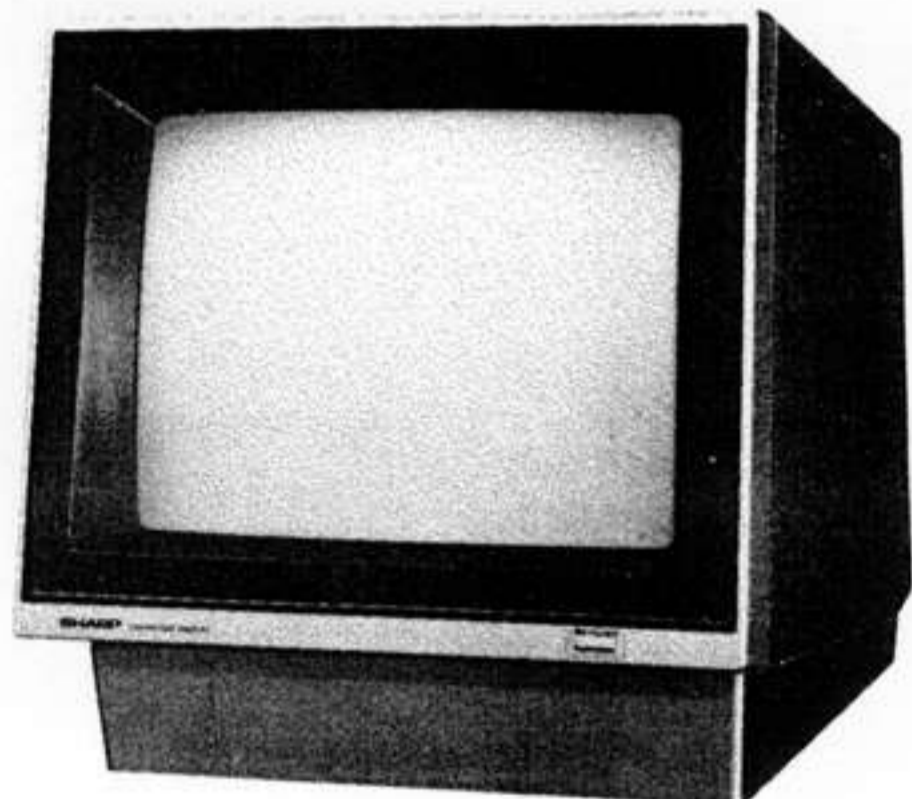

COLOR DISPLAY UNIT MODEL **MZ-1D05**

PRODUCT OUTLINE

The MZ-1D05 is the 14" color display unit designed for personal computer terminal. *MZ-700*
It is driven by three independent video signal inputs of R, G, B, and separate synchronous signal inputs of H and V. Input signals are supplied through the round 8-pin DIN connector.

SPECIFICATION

Input frequency band:	Video signal frequency	Supply power:	220V (50Hz)
Video signal input circuit:		Cabinet:	Plastic
• Video signal amplifier:	3 stages	Physical dimensions:	36.4 (w) x 42.5 (d) x 37.0 (h)cm
• Vertical oscillator:	CR oscillation	Weight:	13.5Kg
• Horizontal oscillator:	CR oscillation	Input signal cable:	Round 8-pin DIN connector
• Pincushion distortion corrector	Right-to-left saturable reactor type	• Video signal input:	R, G, B three independent input method Input level of 2.4 to 5Vp-p positive polarity
• Power rectifier:	Capacitor input bridge rectifier	• Synchronous signal input:	H, V separate synchronous signal input method Input level of 2.4 to 5Vp-p negative polarity
• Power stabilizer:	SCR phase control	AC cord:	3 core wires, 2m, with detachable plug
• Demagnetizer:	Automatic posistor	Accessories:	Instruction manual and AC cord
Display tube:	12", 90 degree deflection 320MAB22		
Display tube size:	21.8 wide x 21.1 high x 33.5 diagonal (cm)		
Power consumption:	58W		
High voltage output:	22KV		
ICs:	4 chips		
Transistors:	15 pcs		
Diodes:	35 pcs		
SCR:	1 pc		

OBSERVANCE OF CASUALTY-FREE JOB AND CHECK-OUT OF SAFETY PERFORMANCE

1. Strict observance of given cautions

Those sections that require special attention (i.e. cabinet, chassis, and component parts) are cautioned on label or by stamp. Job has to be carried out in accordance with those cautions and others mentioned in the instruction manual.

2. Use of genuine parts

Component parts are manufactured in compliance with safety requirements pertinent to individual parts (i.e. non-inflammability, voltage withstanding property, etc.). In this view, component replaced must be identical to the original parts in its characteristics. As critical components required for safety performance are noted with "A." mark in the circuit diagram and parts list, they must be replaced with the genuine parts.

3. Proper replacement of removed components and wirings

For safety's purpose, some of items are insulated with such as tube or tape, or isolated from the printed card. As for wirings, they must be replaced on original positions, as they have been installed for free of heat and high tension, taking their routes into consideration and by supporting them with such as clamps.

4. Careful handling of video tube

Because the explosionproof video tube is in use, it will be safe against explosion, so as long it is installed in the cabinet. But, sufficient care must be paid to avoid shock to the cone of the tube in working on the core from the back of the unit or when the tube is removed from the unit.

5. Radioactive hazard

As safety means are implemented for the video tube and the high tension peripheral circuits in order to protect radioactive hazard, use of the genuine parts becomes necessary in repairing the high tension peripheral circuits. It is also mandatory to avoid any circuit modification. Use of components of any other make may increase voltage in high tension line which may cause to emit radioactive ray from the video tube.

6. Safety check-out

Before completion of your job, you must ensure that such screws, components, and wirings that removed during servicing have been properly replaced on their original locations and see that there is no damage around the serviced area. Also, check insulation among input signal terminal, external metallic portion, and cable plug. Safety performance must be ensured at all times before completion of your job.

How to select supply voltage setup

Power supply setup must be done in the following manner according to the power source rating.

- For 220V region: change K701 plug to K703.
- For 240V region: change K701 plug to K704.

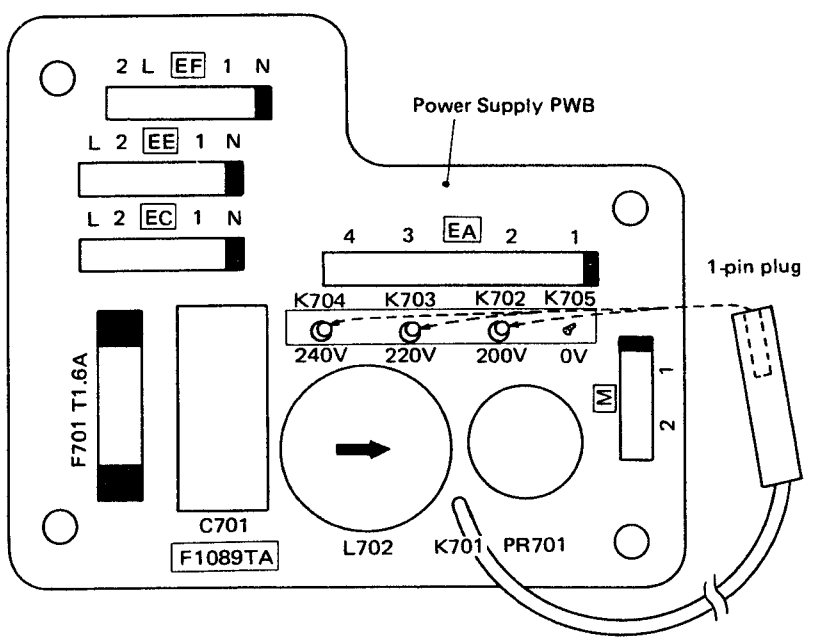

1. PARTS IDENTIFICATION

FRONT SIDE

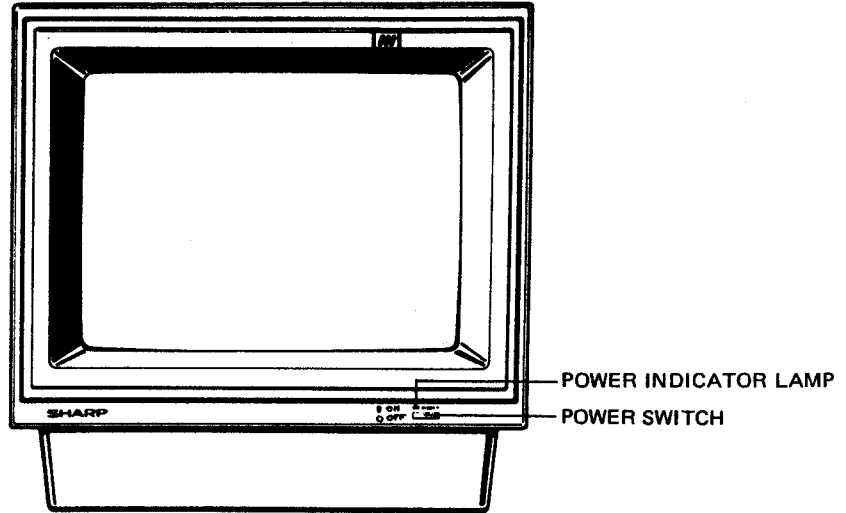

REAR SIDE

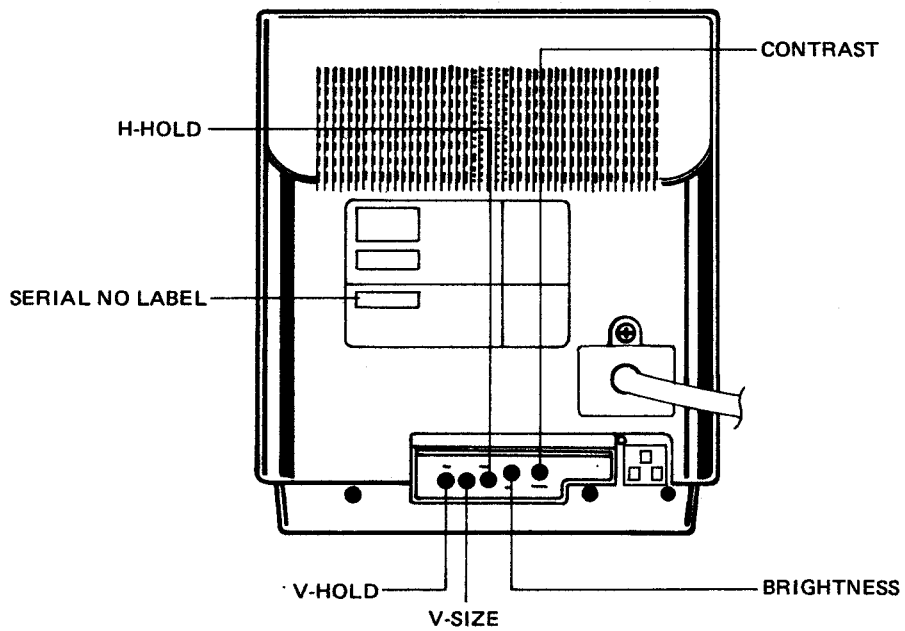

Figure 1.

2. REMOVING MAIN PARTS COMPONENTS

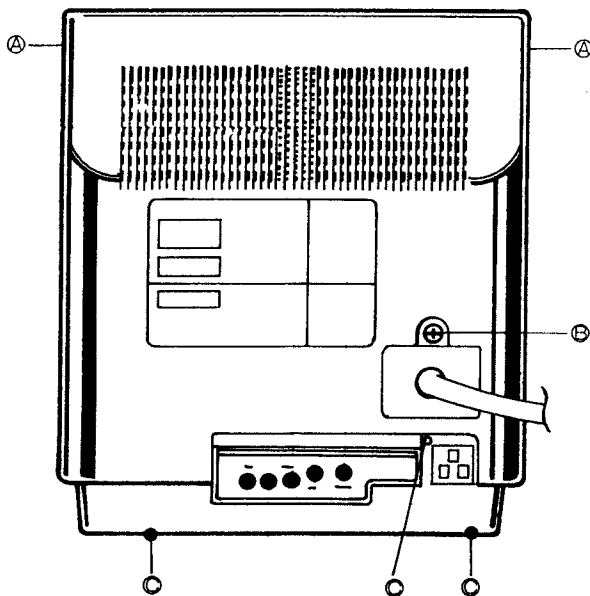

Figure 2.

■ Removal of the rear cover

- 1) Disconnect the AC cable.
- 2) Untighten two screws that secure the upper part ① and two other screws that secure the lower part ② of the rear cover.
- 3) Remove the screw ③ then pull off rear cover.
- 4) Untighten the screw ④.

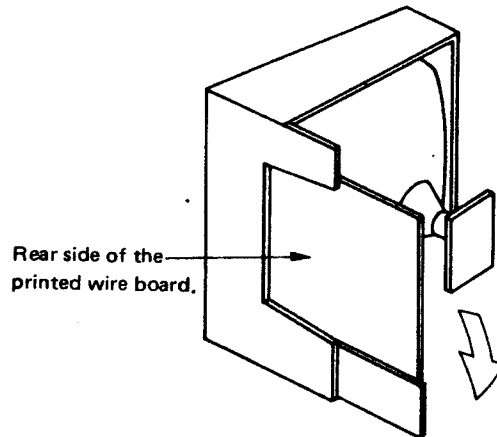

Figure 3.

3. ADJUSTMENTS

- It needs a personal computer (i.e. MZ-700) to carry out adjustments.
- Even though everything had been adjusted to their optimum points before the unit left the factory, it has to be adjusted in the following manner whenever parts replacement is done or when an adjustment error should occur.

● +B power supply circuit (It needs the voltmeter with internal resistance of 20kohms/V.)

- (1) Ensure that the ac supply is above the rating below, depending on power source rating.
228V for 240V set 209V for 220V set.
- (2) Adjust the +B potentiometer so that there should appear the dc voltage of 110V between TP-91 and ground.

NOTE-1) Supply of required 110V may not be obtained when the source voltage is under the given rating, but there would be no specific problem.

NOTE-2) Turning the +B potentiometer clockwise increases the +B voltage. Watch the voltmeter while adjusting so as to avoid too much voltage increase.

● Adjusting horizontal synchronization

- (1) Set the personal computer so that the same letter should be displayed on an entire screen area (on an entire data display period: horizontal 36.088 μ sec, vertical 12.811msec), using such as alphabet letter of "H" (see Test signal 1).
- (2) Adjust the H-HOLD knob so that the picture should situate in a middle of the screen.
- (3) Try to turn on and off power for a few times to see that the picture is stayable.

● Adjusting horizontal amplitude

- (1) Set the personal computer so that the letter "H" should be displayed on an entire screen area (on an entire data display period: horizontal 36.088 μ sec, vertical 12.811msec) (see Test signal 1).
- (2) Adjust the horizontal amplitude coil so that the amplitude on the center should become 245mm.

NOTE) Turning the horizontal amplitude coil clockwise will make amplitude increased.

● Adjusting vertical amplitude

- (1) Set the personal computer so that the letter "H" should be displayed on an entire screen area (on an

entire data display period: horizontal 36.088 μ sec, vertical 12.811msec) (see Test signal 1).

• **Adjusting white balance**

- (1) Turn the SCREEN knob fully counterclockwise, each of RED, GREEN, and BLUE bias knobs fully clockwise, the BRIGHT knob fully clockwise (maximum), and the RED/BLUE knob to a midway position.
- (2) Set the personal computer so that an entire screen area (on an entire data display period: horizontal 36.088 μ sec, vertical 12.811msec) should become all white (see Test signal 2).
- (3) Pull out the service chip (V1).
- (4) Turn the SCREEN knob clockwise until a single color raster becomes slightly visible.
- (5) Turn the BIAS knobs of two other suppressed colors counterclockwise so that raster should appear white (gray). Slightly decrease the SCREEN knob until raster disappears.
- (6) Replace the service chip (V1).
- (7) Manipulate the personal computer so that an entire screen area (on an entire data display period: horizontal 36.088 μ sec, vertical 12.811msec) should remain

- (2) Adjust the V-AMP knob so that the amplitude at the center of the picture should become 183mm.

all white (see Test signal 2).

- (8) Adjust by means of the RED/BLUE knob so the raster should turn white.
- (9) Set the BRIGHT knob to the maximum position, then adjust the SUB-BRIGHT knob (R419) so that dc 5.6V should appear between TP-402 and TP-403.
- (10) Try to vary the position of the BRIGHT knob to ensure white balance at both extremes of bright and dark.
- (11) Repeat Steps (3) through (10) above to attain complete adjustment.

• **Adjusting focus**

- (1) Set the personal computer and bring letters appear on the display (see Test signal 1).
- (2) Set the BRIGHT knob to the maximum position.
- (3) Adjust the FOCUS knob to obtain an optimum of focus.
- (4) Manipulate the BRIGHT knob to see that it is in an optimum of focus.

Test signal (ex: MZ-700)

Test signal 1 (1000 characters, H signal)

```
(EX.) 10 PRINT CHR$(6)
      20 FOR I=1 TO999
      30 PRINT "H";
      40 NEXT I
      50 GO TO 50
```

Test signal 2 (WHITE signal)

```
(EX.) 10 FOR I=1 TO 7
      20 COLOR ...I
      30 PRINT "□"
      40 GET AS$
      50 IF AS$=" " THEN 70
      60 GO TO 40
      70 NEXT I
      80 COLOR ...0
      90 PRINT "□"
     100 END
```

4. TROUBLESHOOTING

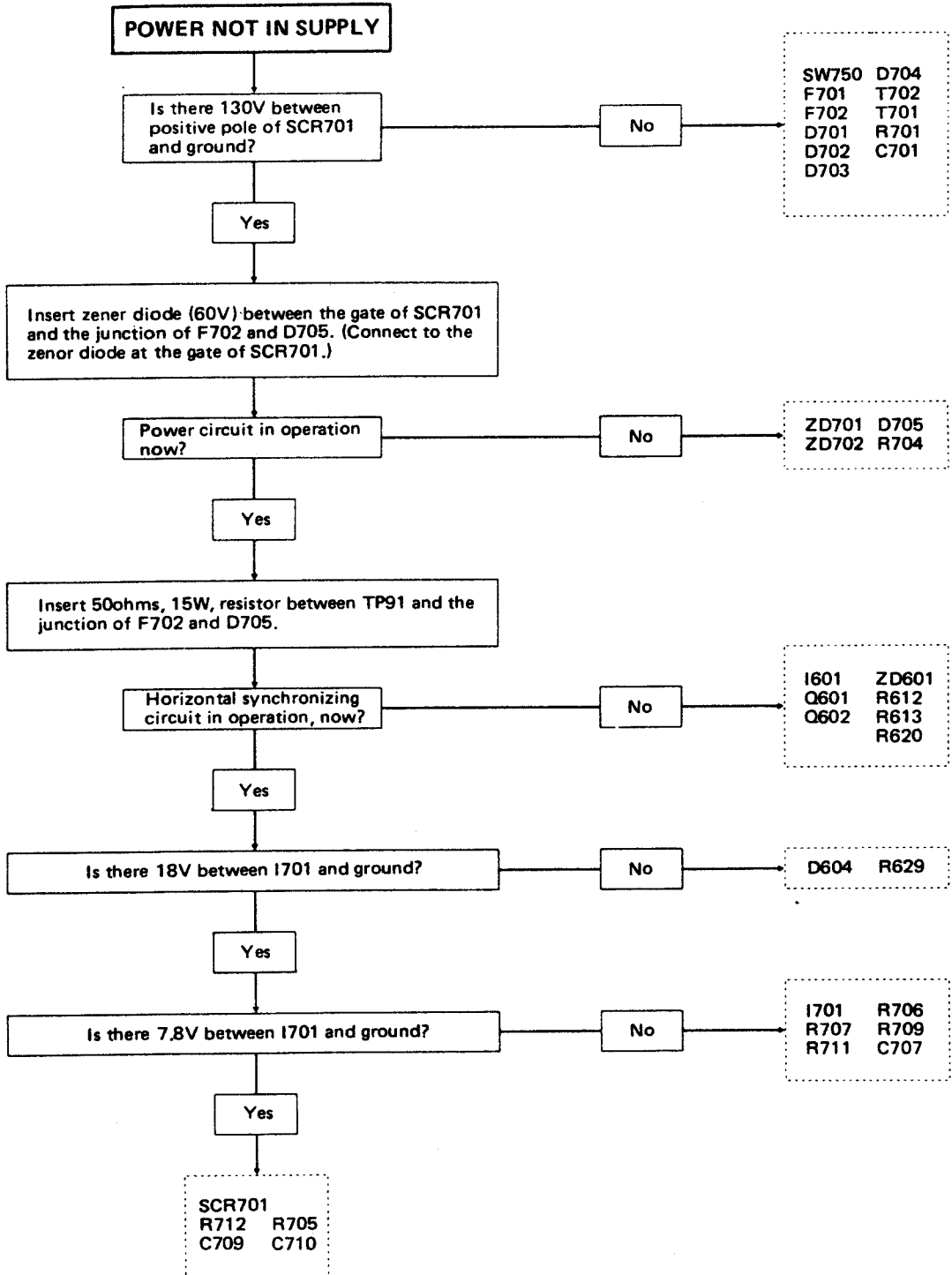

RASTER DOES NOT APPEAR

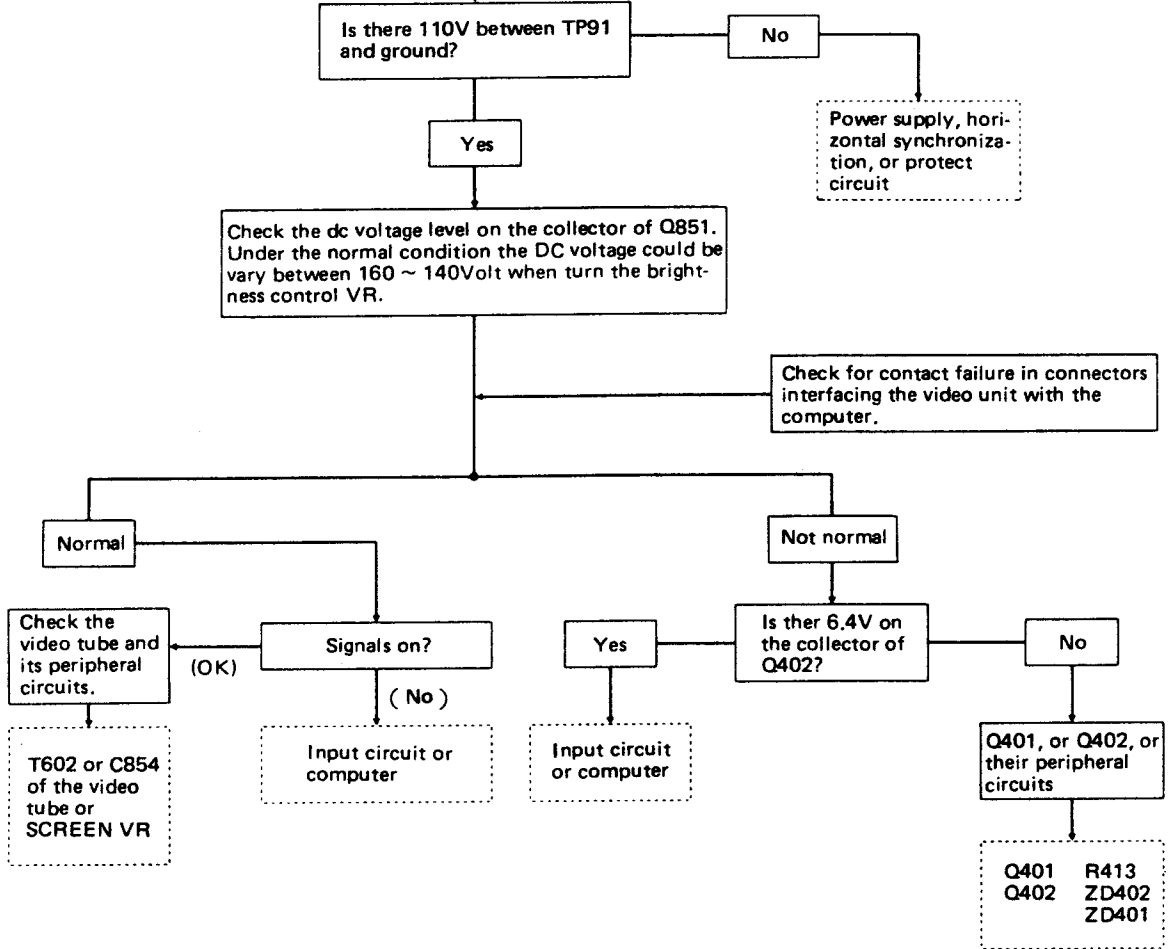

PICTURE DOES NOT APPEAR

NOTE: In case picture does not appear on the screen, try to turn the BRIGHT knob fully clockwise before check.

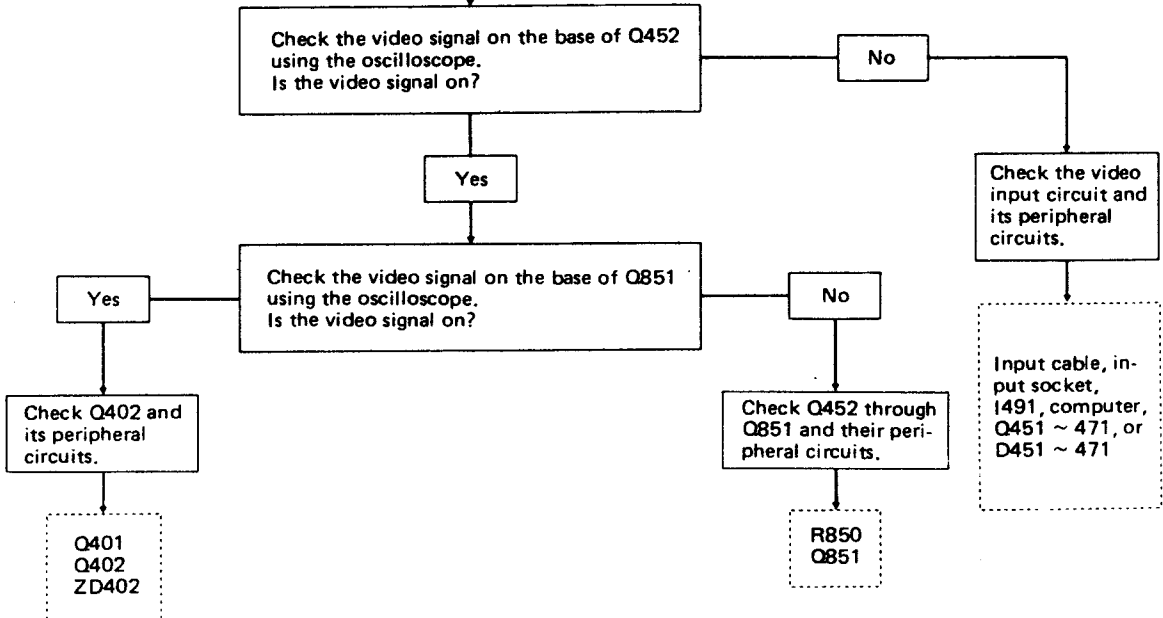

SYNCHRONIZATION DISABLED

I481 I601 R608
R481 R602 C601
R483

Horizontal or vertical
synchronization not
enabled.

**HORIZONTAL SYNCHRONI-
ZATION NOT ENABLED**

If vertical synchroni-
zation is normal.

Check appearance of sawteeth waveform
and synchronization signals on pin 14 of
I601.

Yes

No

I601
R605
R606
R607

I601

Manipulate H-HOLD to see if a change is
met in the horizontal synchronizing fre-
quency.

Yes

No

C604
C606

I601
R612
R607

**VERTICAL SYNCHRONIZATION
NOT ENABLED**

If horizontal synchroni-
zation is normal.

Vertical synchronization not possible to
adjust.

I601 C501
R502 C504

A slight change may be met in the fre-
quency of vertical synchronization.

I601 R513
R510 R514
R511 C503
R512 C505

VERTICAL SWEEP NOT ENABLED

IMPORTANT: Decrease brightness
during the check to
avoid damaging the
video tube.
NOTE: Ripple current signal
appears on the junction
of F702 and R703.

Send ripple current signal to pin 2 of I601
via the serial connected resistor (1 kohms)
and capacitor (10 μ F).

Raster is swept verti-
cally.

I601 R508 R511
R504 R509 R512
R505 R501 R513
R506 C503 R514
R507 R506 R515

Does not sweep.

I601 D502 R508 C509
Q501 D503 R516 C510
Q502 R503 R518 C514
DY601 R504 R519
D504 R507 R520
R505 R507 R524

5. SCHEMATIC DIAGRAM AND WAVEFORMS

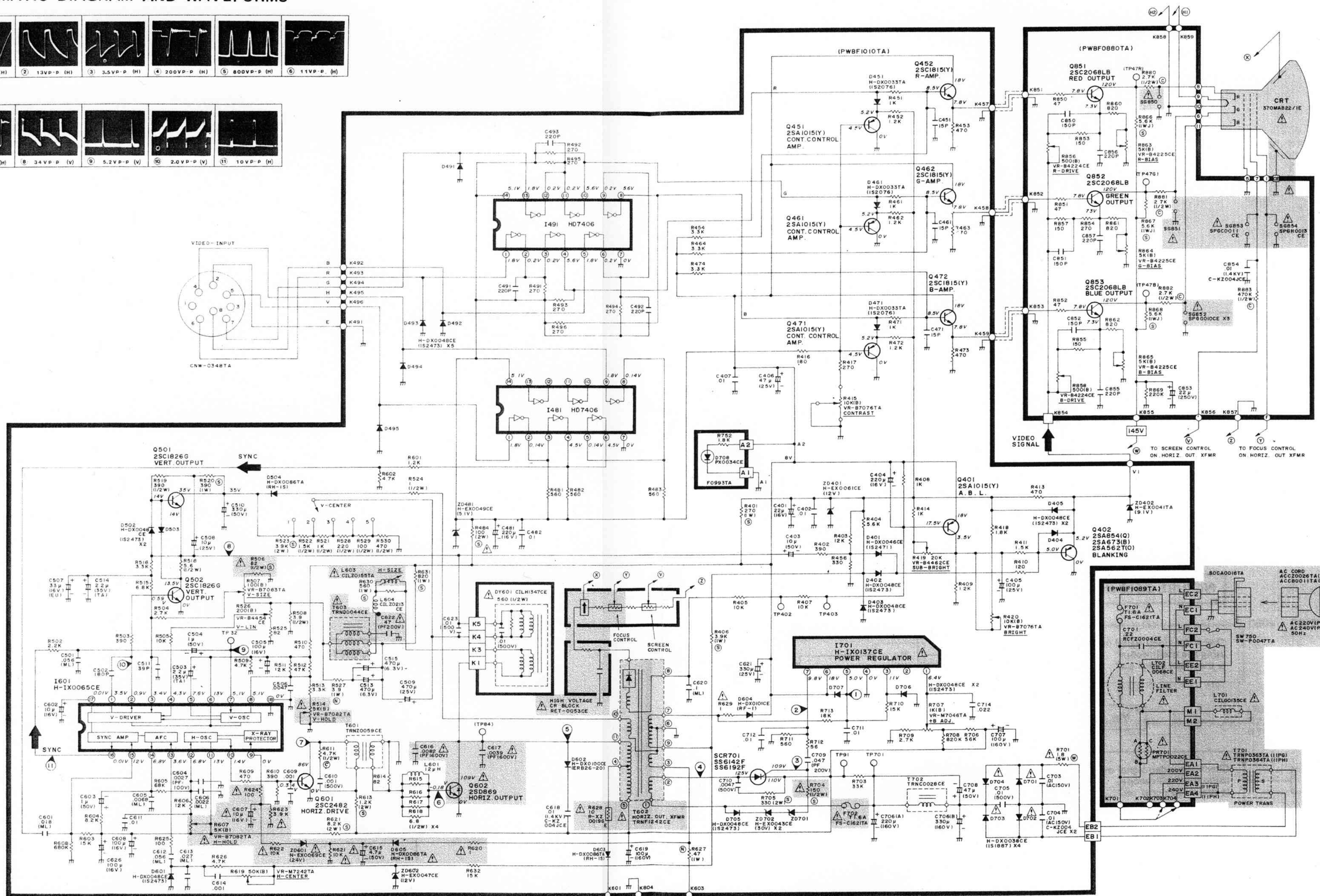
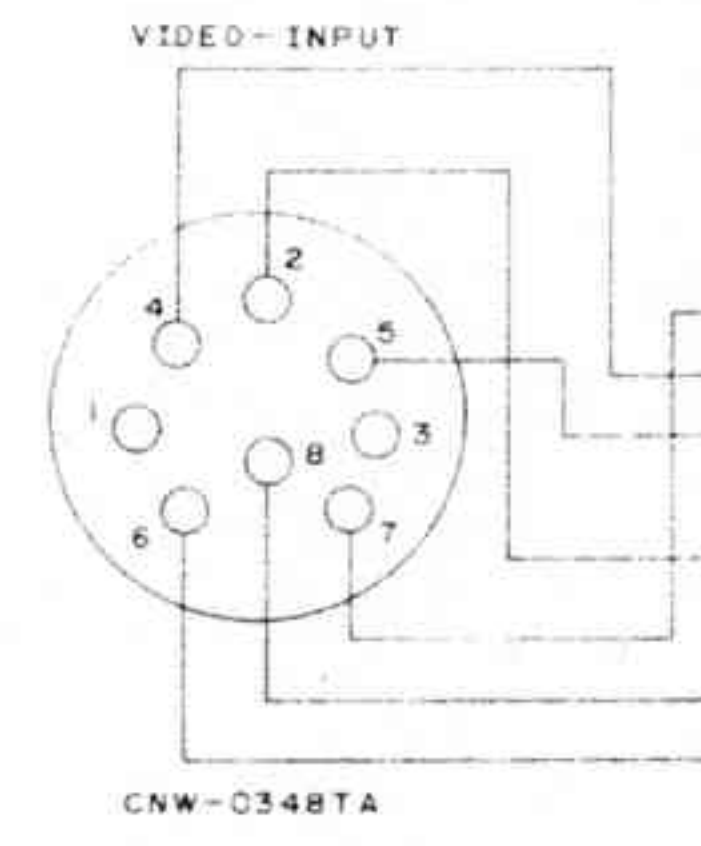
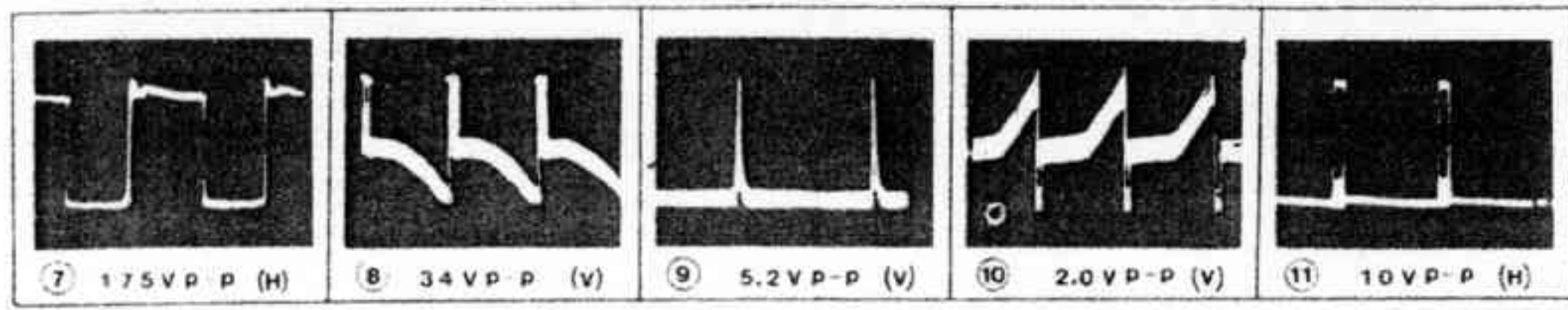
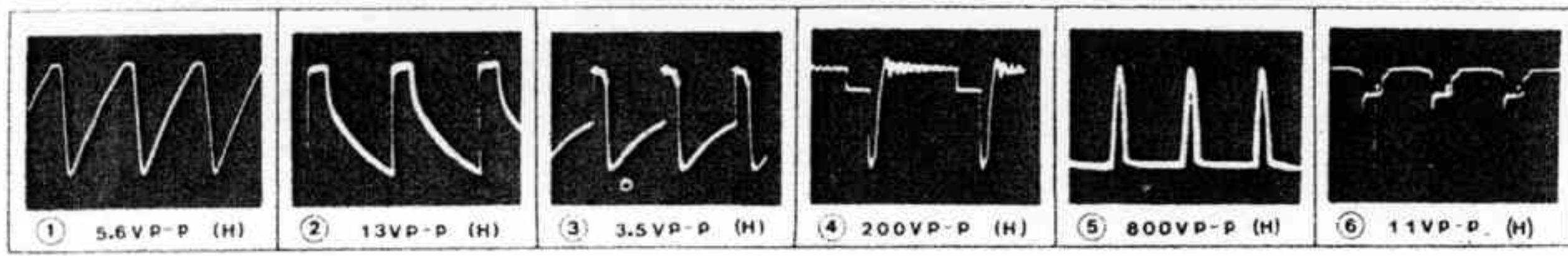

6. PRINTED WIRING BOARD ASSEMBLIES

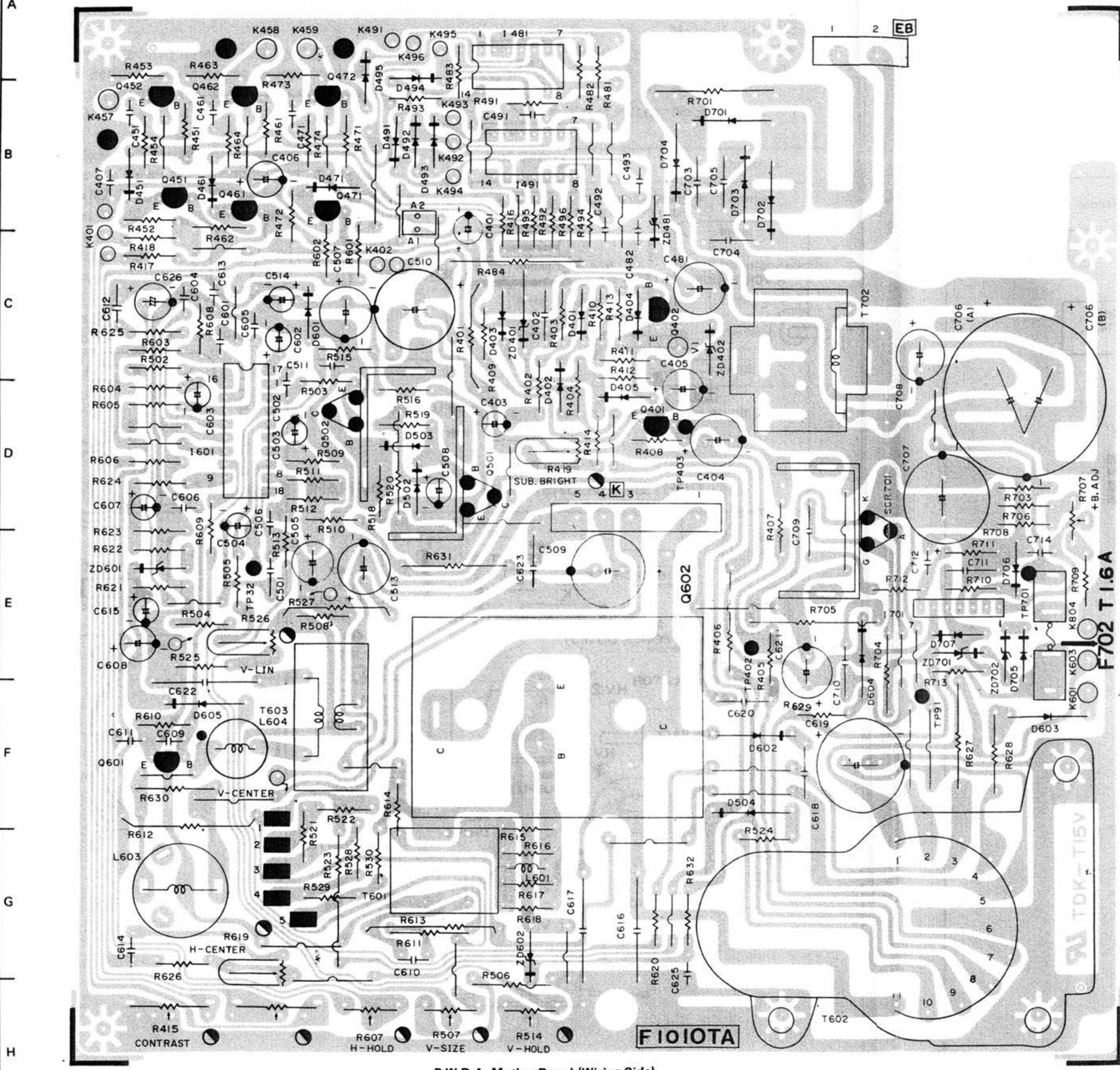

P.W.B-A Mother Board (Wiring Side)

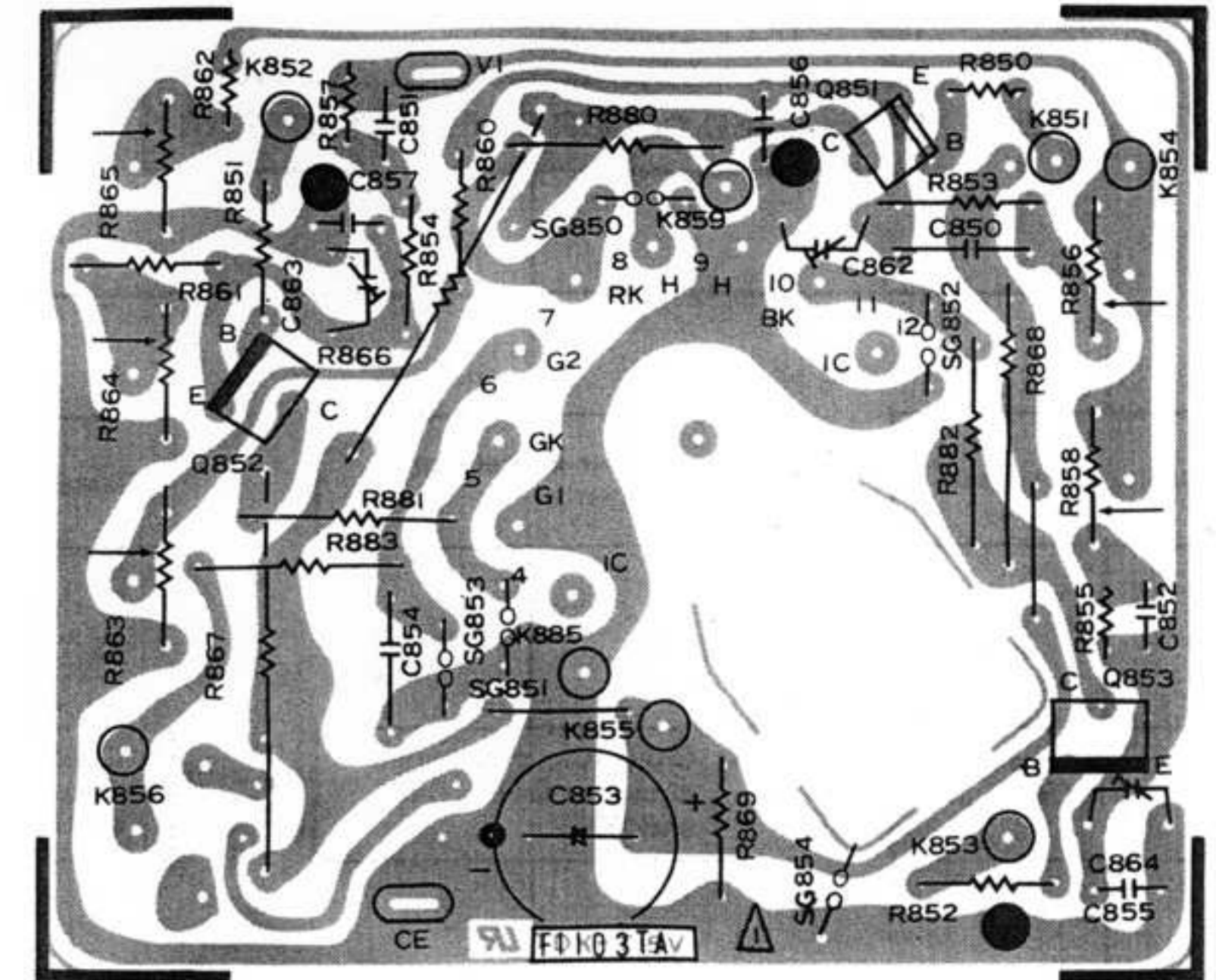

P.W.B-B CRT Socket Board (Wiring Side)

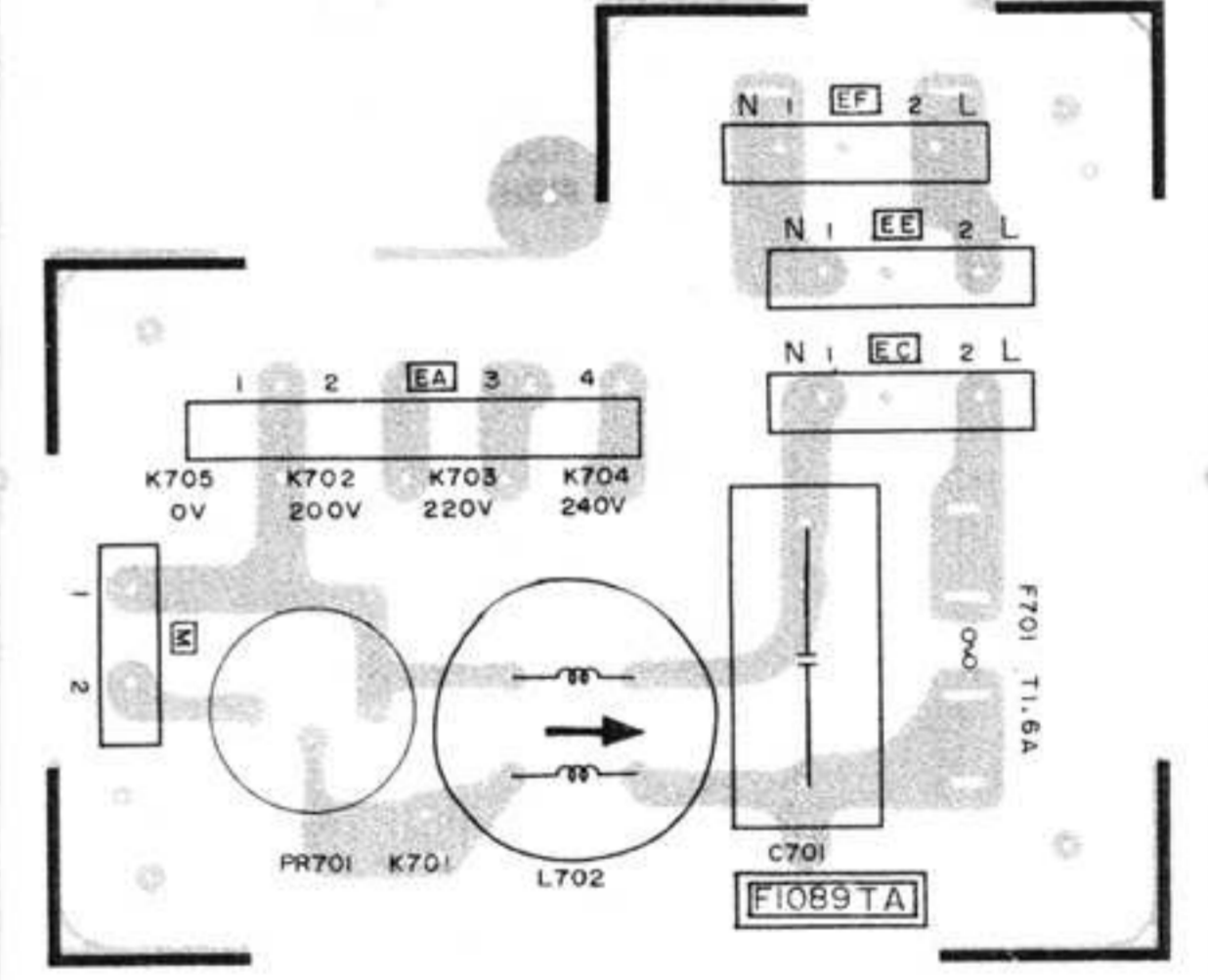

Power Supply P.W.B.

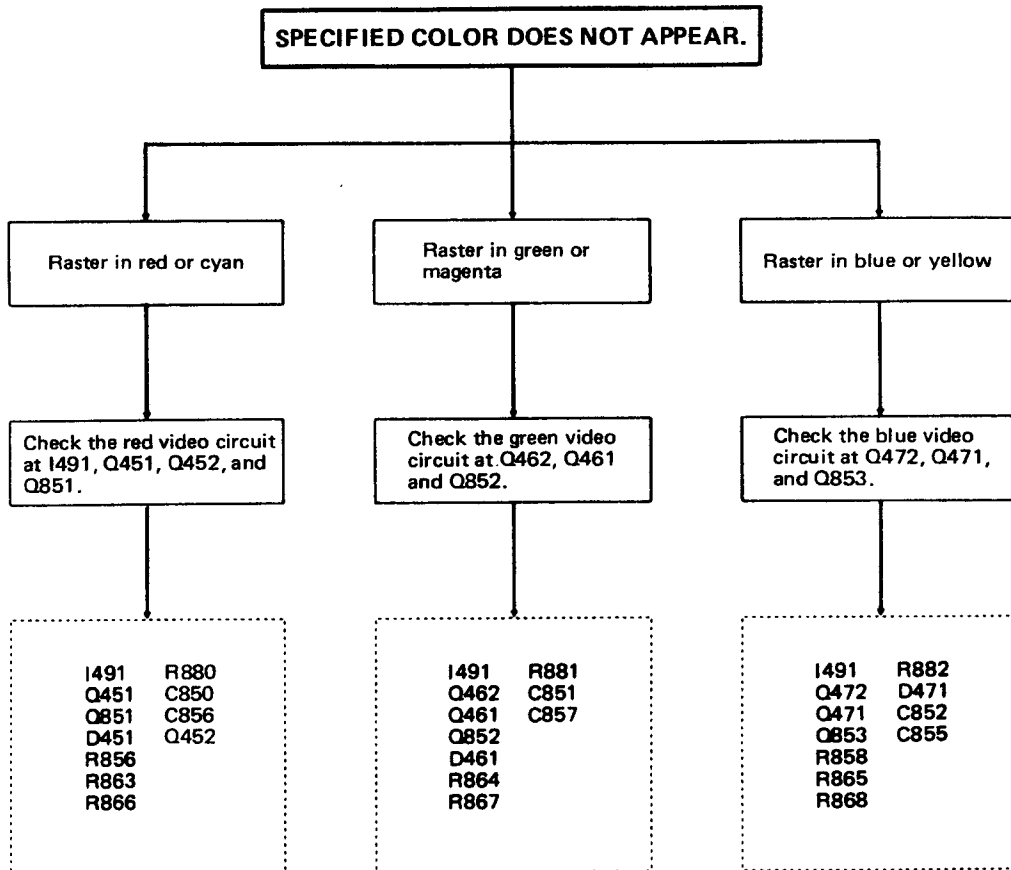

7. CHASSIS LAYOUT

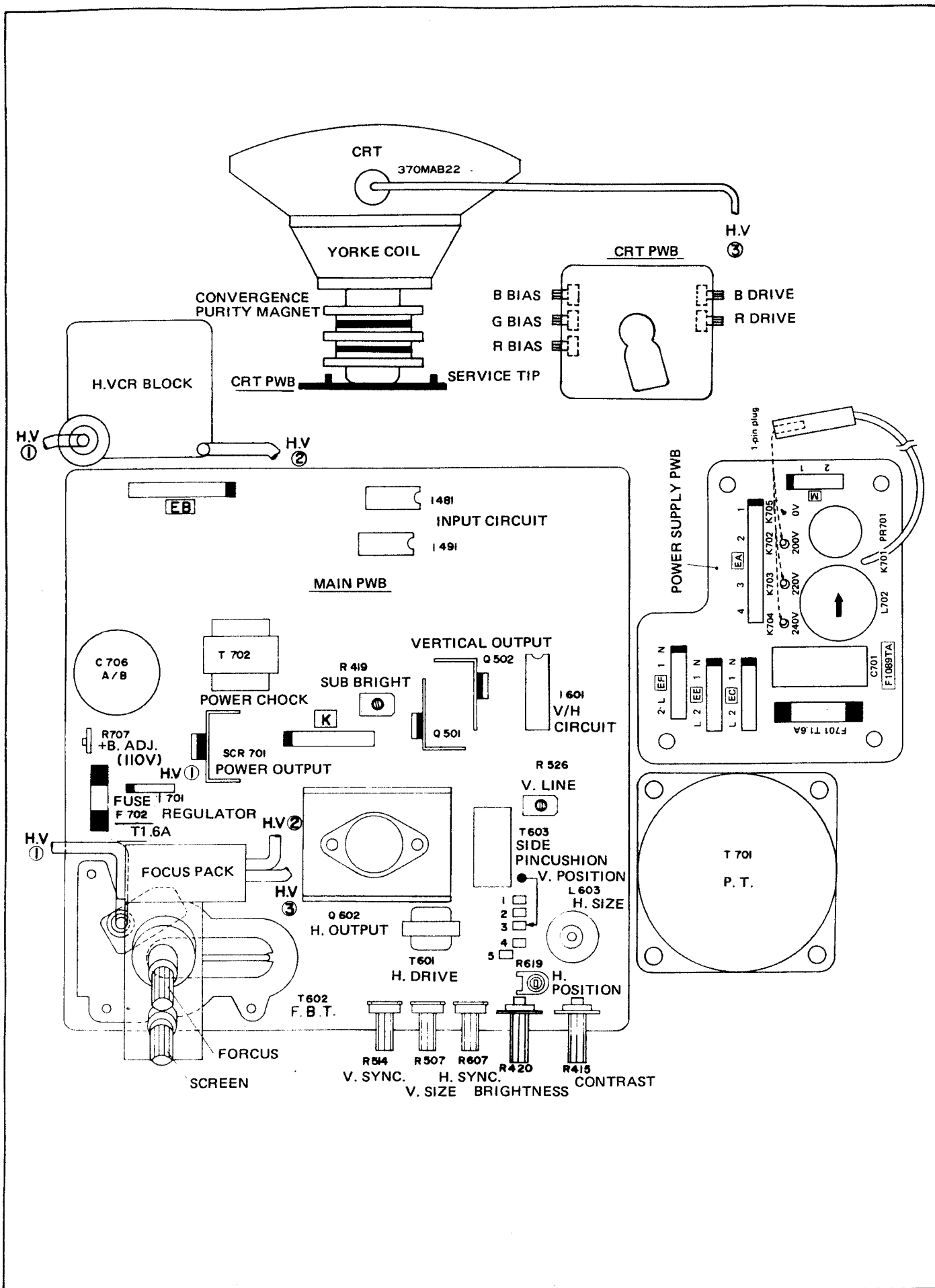

NOTES ON WIRING DIAGRAM

*There may be a slight difference depending on the serial number, because this wiring diagram is the basic wiring diagram.

Since the parts component noted with a "Δ" mark is critical for safety performance, it has to be replaced with the genuine parts for safety's sake, as well as maintaining proper performance of the unit.

1. Voltage values and waveforms indicated in the wiring diagram are the values that measured with the personal computer (MZ-700) in connection and with the video input signal of 0V (screen not working), under the given rating.

NOTE-1: Voltage value is the value measured by the 20kohms/V voltmeter.

NOTE-2: (H) and (V) in waveform description represent repeat frequency.
(H): 15.61Hz, (V): 50.0Hz

2. Resistor and capacitor rating description

- | | | |
|-----------|------------------|------------------------|
| Resistor | ● Capacity: | No mark: ohms K: Kohms |
| | | M: Mohms |
| | ● Error | No mark: ±10% J: ±5% |
| Capacitor | ● Capacity: | No mark or μ: μF |
| | | P: pF |
| | ● Rated voltage: | No mark: 50V |

[Type]

Resistor		Capacitor	
No mark	Carbon film	No mark	Ceramic
C	Solid	ML	Mylar
S	Metal oxide film	PF	Polypropylene film
N	Metal film		Film
W	Cement	TA	Tantalum
T	Special	ST	Styrol

3. Test point noted in parenthesis has no pin.

8. LEAD WIRE SHAPING AND WIRE THREADING METHOD

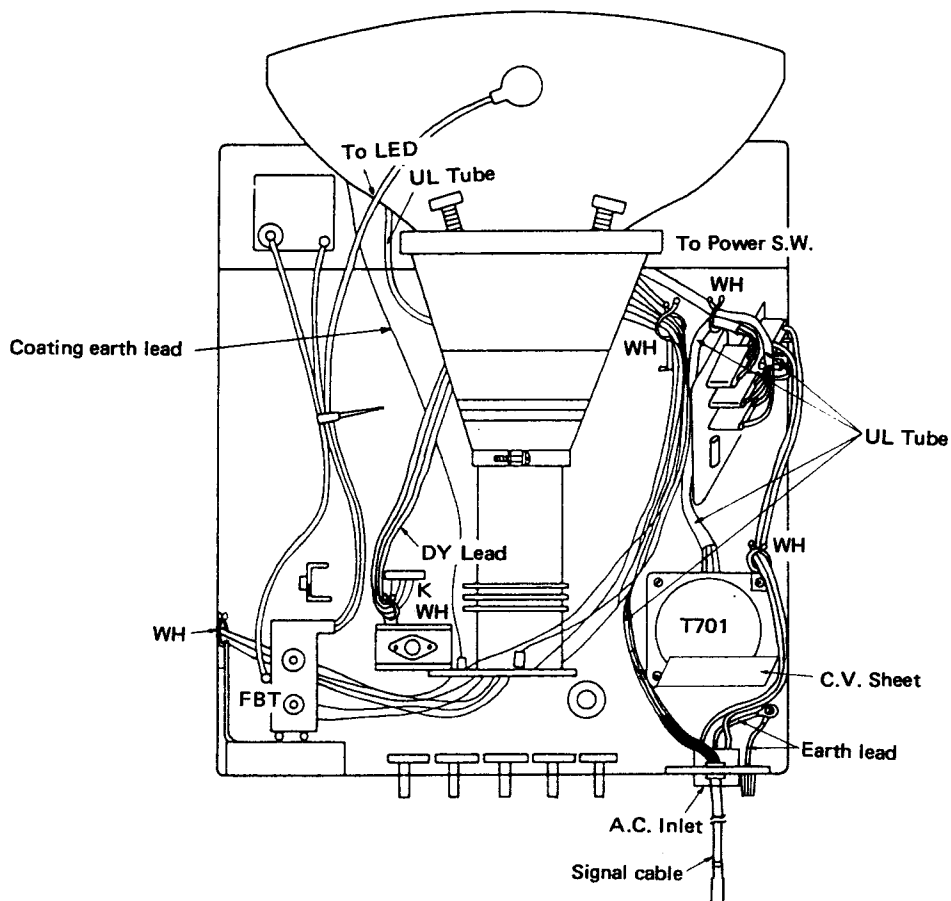

9. PACKING OF THE SET

• Knob Positions

POWER	OFF
H-CENTER	BEST
V-HOLD	NORMAL
BRIGHT	BEST

Accessories

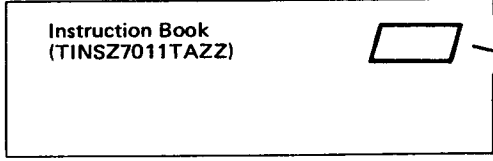

Poly. bag (SSAKA0003GEZZ)

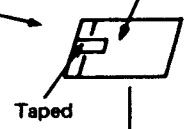

Dust cover (SPAKP6416TAZZ)

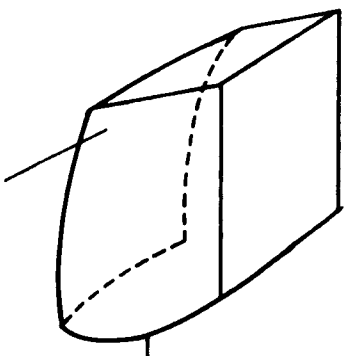

Cushion (SPAKA6416TAZZ)

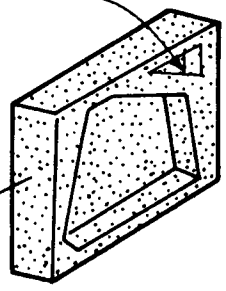

Printed material in the bag is contained.

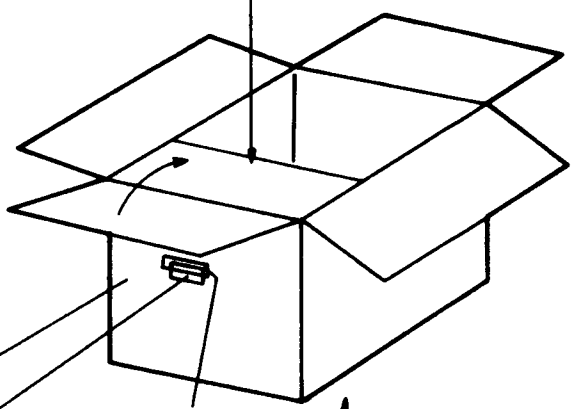
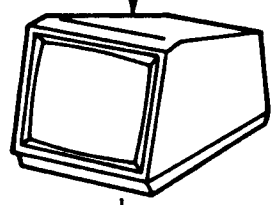
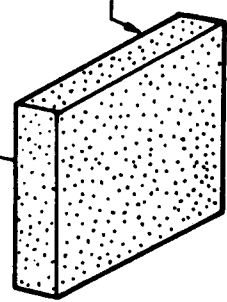

Carton
 Europe Except UK (SPAKC7011TAZZ)
 UK only (SPAKC7010TAZZ)

Serial number card (TLABK0001TAZZ)

Taped

Top and bottom are stapled.

PARTS LIST

1 Tube, IC

NO.	PARTS CODE	PRICE RANK	NEW MARK	PART RANK	DESCRIPTION
1	VB370MAB22/1E	**		B	Picture tube [I601]
2	RH-iX0065CEZZ	AM		B	IC(H-AND-V) [I701]
3	RH-iX0137CEZZ	AG		B	IC(SCR Power) [I481/491]
4	VHiHD7406//1	AF		B	IC

2 Transistors

NO.	PARTS CODE	PRICE RANK	NEW MARK	PART RANK	DESCRIPTION
1	VHSS6192FLB1E	AM		B	Thyristor [SCR701]
2	VS2SA1015Y/1E	AB		B	Transistor [Q401,451,461,471]
3	VS2SA854-Q/1E	AC		B	Transistor [Q402]
4	VS2SC1815YW-1	AB		B	Transistor [Q452,462,472]
5	VS2SC1826GL2E	AG		B	Transistor [Q501,Q502]
6	VS2SC2068LB1E	AF		B	Transistor [Q851,852,853]
7	VS2SC2482//1	AD		B	Transistor(H-Drive) [Q601]
8	VS2SD869-//1E	AM		B	Transistor [Q602]

3 Diodes and LED'S

NO.	PARTS CODE	PRICE RANK	NEW MARK	PART RANK	DESCRIPTION
1	RH-DX0033TAZZ	AA		B	Diode [D451,461,471]
2	RH-DX0038CEZZ	AB		B	Diode [D701~704,1S1887]
3	RH-DX0046CEZZ	AB		B	Diode [D401]
4	RH-DX0048CEZZ	AA		B	Diode [D402~405]
5	RH-DX0086TAZZ	AC		B	Diode [D603,605,504]
6	RH-DX0100CEZZ	AF		B	Diode [D602 BOOST]
7	RH-DX0101CEZZ	AD		B	Diode [D604,FR-1]
8	RH-EX0041TAZZ	AB		B	Zener diode [ZD402]
9	RH-EX0043CEZZ	AB		B	Zener diode [ZD701,702]
10	RH-EX0047CEZZ	AB		B	Zener diode [ZD602]
11	RH-EX0049CEZZ	AB		B	Zener diode [ZD481]
12	RH-EX0061CEZZ	AD		B	Zener diode [ZD401]
13	RH-EX0069CEZZ	AB		B	Zener diode [ZD601]
14	RH-PX0034CEZZ	AD		B	Photo transistor [D708]

4 Packaged circuits

NO.	PARTS CODE	PRICE RANK	NEW MARK	PART RANK	DESCRIPTION
1	RMPTP0022CEZZ	AN		B	Block resistor [PR701]

5 Coil and Transformers

NO.	PARTS CODE	PRICE RANK	NEW MARK	PART RANK	DESCRIPTION
1	RCiLF0068CEZZ	AH		C	Coil [L702]
2	RCiLG0135CEZZ	AM	N	C	Degaussing coil [ADG L701]
3	RCiLH1347CEZZ	BG	N	B	Deflection yoke [DY 601]
4	RCiLZ0155TAZZ	AN		C	Coil(H-Size) [L603]
5	RCiLZ0213CEZZ	AG		C	Coil [L604]
6	RTRNC0028CEZZ	AK		B	Choke transformer(+B-Choke) [T702 +B]
7	RTRNF1242CEZZ	BG		B	H-VOLT transformer [T602]
8	RTRNP0363TAZZ	BL		B	Power transformer(Europe except U.K) [T701]
9	RTRNP0364TAZZ	BL		B	Power transformer(U.K. only) [T701]
10	RTRNQ0044CEZZ	AL		B	Pin-Cushion trans(Side-Pin) [T603]
11	RTRNZ0059CEZZ	AG		B	Transformer(Drive) [T601]
12	VP-LK120K0000	AB		C	Peaking coil [L601]

6 Controls

NO.	PARTS CODE	PRICE RANK	NEW MARK	PART RANK	DESCRIPTION
1	RVR-B4224CEZZ	AD		B	Variable resistor(Drive) [R856,858]
2	RVR-B4225CEZZ	AD		B	Variable resistor [R863~865]
3	RVR-B4454CEZZ	AC		B	Variable resistor(V-Line) [R526 200B]
4	RVR-B4462CEZZ	AC		B	Variable resistor(SUB BRIGHT) [R419]
5	RVR-B7076TAZZ	AE		B	Variable resistor [R415,420]
6	RVR-B7082TAZZ	AD		B	Variable resistor [R514,607]
7	RVR-B7083TAZZ	AD		B	Variable resistor [R507]
8	RVR-M7046TAZZ	AC		B	Variable resistor(+B ADJ) [R707]
9	RVR-M7242TAZZ	AC		B	Variable resistor(H-CENT) [R619]

7 Capacitors

NO.	PARTS CODE	PRICE RANK	NEW MARK	PART RANK	DESCRIPTION
1	RC-FZ0004CEZZ	AH		C	Capacitor [C701]
2	RC-KZ004JCEZZ	AC		C	Capacitor [C703,704,618]
3	VCCSPA1H6150J	AA	N	C	Capacitor (50WV 15pF) [C451,461,471]
4	VCCSPA1H0221J	AA	N	C	Capacitor (50WV 220pF) [C855~857]
5	VCCSPA1H6181K	AA	N	C	Capacitor (50WV 180pF) [C502]
6	VCCSPA1H6390K	AA	N	C	Capacitor (50WV 39pF) [C511]
7	VCEAAU0JW477M	AC		C	Capacitor (6.3WV 470μF) [C513]
8	VCEAAA1CW106M	AC		C	Capacitor (16WV 10μF) [C602,607]

7 Capacitors

NO.	PARTS CODE	PRICE RANK	NEW MARK	PART RANK	DESCRIPTION
9	VCEAAA1CW107M	AB		C	Capacitor (100 μ F 16V) [C505,608,626]
10	VCEAAA1CW226M	AB	N	C	Capacitor (16WV 22 μ F) [C401]
11	VCEAAA1CW227M	AC		C	Capacitor (220 μ F 16V) [C404,481]
12	VCEAAA1FW106M	AB	N	C	Capacitor (25WV 10 μ F) [C508]
13	VCEAAU1EW107M	AB		C	Capacitor (25WV 100 μ F) [C405]
14	VCEAAA1EW337M	AD		C	Capacitor (25WV 330 μ F) [C621]
15	VCEAAA1EW476M	AB	N	C	Capacitor (25WV 47 μ F) [C406]
16	VCEAAU1EW477M	AD		C	Capacitor (25WV 470 μ F) [C509]
17	VCEAAA1HW105M	AB		C	Capacitor (50WV 1 μ F) [C504,603]
18	VCEAAA1HW106M	AB		C	Capacitor (50WV 10 μ F) [C403]
19	VCEAAA1HW337M	AD		C	Capacitor (50WV 330 μ F) [C510]
20	VCEAAU1HW475M	AB		C	Capacitor (50WV 4.7 μ F) [C615]
21	VCEAAA1HW476M	AC	N	C	Capacitor (50WV 47 μ F) [C708]
22	VCEAAH2CW107Y	AF		C	Capacitor (160WV 100 μ F) [C707/619]
23	VCEAAH2EW226Y	AE		C	Capacitor (250WV 22 μ F) [C853]
24	VCEAAU0JW477M	AC		C	Capacitor (6.3WV 470 μ F) [C515]
25	VCEACA1CC336K	AD	N	C	Capacitor (16WV 33 μ F) [C507]
26	VCEHAQ2CBA31Y	AN		C	Capacitor (160WV) [C706(A),(B)]
27	VCFPPD2DB474J	AF		C	Capacitor (200WV 0.47 μ F) [C622]
28	VCFPPD3CA822J	AE	N	C	Capacitor (1600WV 8200pF) [C616]
29	VCFPPD3CB392J	AD	N	C	Capacitor (1600WV 3900pF) [C617]
30	VCKYAT1EX103N	AA		C	Capacitor (25WV 0.01 μ F) [C402]
31	VCKYAT1HB151K	AA	N	C	Capacitor (50WV 150pF) [C850]
32	VCKYPA2HB102K	AA		C	Capacitor (500WV 1000pF) [C610]
33	VCKYPA2HB472K	AB		C	Capacitor (500WV 4700pF) [C710]
34	VCKYPB2HB103K	AC		C	Capacitor (500WV 0.010 μ F) [C705/623]
35	VCKZPA1HB102K	AA	N	C	Capacitor (50WV 1000pF) [C609/614]
36	VCKZPA1HB103K	AA	N	C	Capacitor (50WV 0.010 μ F) [C711/712/482/611]
37	VCKZPA1HB151K	AA	N	C	Capacitor (50WV 150pF) [C851,C852]
38	VCKZPA1HB221K	AC		C	Capacitor (220pF 50V) [C491~493]
39	VCKZPA1HB472K	AA	N	C	Capacitor (50WV 4700pF) [C506]
40	VCKZPA1HF103Z	AA		C	Capacitor (50WV 0.01 μ F) [C407]
41	VCKZPA1HF223Z	AA	N	C	Capacitor (50WV 0.022 μ F) [C714]
42	VCQPSA2AA272G	AD		C	Capacitor (100WV 2700pF) [C604]
43	VCQPSB2DA473K	AB		C	Capacitor (200WV 0.047 μ F) [C709]
44	VCQYSH1HM104K	AC	N	C	Capacitor (50WV 0.10 μ F) [C620]
45	VCQYSH1HM183K	AB	N	C	Capacitor (50WV 0.018 μ F) [C601]
46	VCQYSH1HM222K	AA	N	C	Capacitor (50WV 2200pF) [C606]
47	VCQYSH1HM273K	AB	N	C	Capacitor (50WV 0.027 μ F) [C613]
48	VCQYSH1HM563K	AB	N	C	Capacitor (50WV 0.056 μ F) [C501,612]
49	VCQYSH1HM682K	AA	N	C	Capacitor (50WV 6800pF) [C605]
50	VCSATA1VE225K	AC	N	C	Capacitor (35WV 2.2 μ F) [C503,514]

8 Resistors

NO.	PARTS CODE	PRICE RANK	NEW MARK	PART RANK	DESCRIPTION
1	RR-XZ0019GEZZ	AB	N	C	Resistor (10 Ω) [R628]
2	VRC-MA2HG272K	AA	N	C	Resistor (1/2W 2.7K Ω \pm 10%) [R880~882]
3	VRC-MA2HG472K	AA	N	A	Resistor (1/2W 4.7K Ω \pm 10%) [R611]
4	VRC-MA2HG474K	AA	N	C	Resistor (1/2W 470K Ω \pm 10%) [R883]
5	VRD-RA2BE182J	AA		C	Resistor (1/8W 1.8K Ω \pm 5%) [R752]
6	VRD-RA2EE1R0J	AA	N	C	Resistor (1/4W 1.0 Ω \pm 5%) [R629,620]
7	VRD-RA2EE101J	AA		C	Resistor (1/4W 100 Ω \pm 5%) [R624,625]
8	VRD-RA2EE102J	AA		C	Resistor (1/4W 1.0K Ω \pm 5%) [R408/451/461/471]
9	VRD-RA2EE103J	AA		C	Resistor (10K Ω 1/4W \pm 5%) [R405,407,622,505]
10	VRD-RA2EE121J	AA		C	Resistor (1/4W 120 Ω \pm 5%) [R410]
11	VRD-RA2EE122J	AA		C	Resistor (1/4W 1.2K Ω \pm 5%) [R409,452,462,472]
12	VRD-RA2EE123J	AA		C	Resistor (1/4W 12K Ω \pm 5%) [R511,606,403]
13	VRD-RA2EE151J	AA	N	C	Resistor (1/4W 150 Ω \pm 5%) [R853]
14	VRD-RA2EE152J	AA		C	Resistor (1.5K Ω 1/4W \pm 5%) [R411]
15	VRD-RA2EE153J	AA	N	C	Resistor (1/4W 15K Ω \pm 5%) [R603,710,632]
16	VRD-RA2EE182J	AA	N	C	Resistor (1/4W 1.8K Ω \pm 5%) [R418]
17	VRD-RA2EE183J	AA	N	C	Resistor (1/4W 18K Ω \pm 5%) [R713]
18	VRD-RA2EE222J	AA	N	C	Resistor (1/4W 2.2K Ω \pm 5%) [R502]
19	VRD-RA2EE224J	AA	N	C	Resistor (1/4W 220K Ω \pm 5%) [R869]
20	VRD-RA2EE271J	AA	N	C	Resistor (1/4W 270 Ω \pm 5%) [R491~494]
21	VRD-RA2EE272J	AA		C	Resistor (1/4W 2.7K Ω \pm 5%) [R504,709]
22	VRD-RA2EE331J	AA	N	C	Resistor (1/4W 330 Ω \pm 5%) [R456]
23	VRD-RA2EE332J	AA		C	Resistor (1/4W 3.3K Ω \pm 5%) [R513,516,454,464]
24	VRD-RA2EE333J	AA	N	C	Resistor (1/4W 33K Ω \pm 5%) [R703]
25	VRD-RA2EE391J	AA	N	C	Resistor (1/4W 390 Ω \pm 5%) [R402,503,610]
26	VRD-RA2EE392J	AA		C	Resistor (1/4W 3.9K Ω \pm 5%) [R623]
27	VRD-RA2EE470J	AA	N	C	Resistor (1/4W 47 Ω \pm 5%) [R851,852]
28	VRD-RA2EE471J	AA		C	Resistor (1/4W 470 Ω \pm 5%) [R413,453,436,473]
29	VRD-RA2EE472J	AA		C	Resistor (1/4W 4.7K Ω \pm 5%) [R509,602,626]
30	VRD-RA2EE473J	AA		C	Resistor (1/4W 47K Ω \pm 5%) [R512]
31	VRD-RA2EE560J	AA		C	Resistor (1/4W 56 Ω \pm 5%) [R712]
32	VRD-RA2EE561J	AA		C	Resistor (560 Ω 1/4W \pm 5%) [R711,481~483]
33	VRD-RA2EE562J	AA	N	C	Resistor (1/4W 5.6K Ω \pm 5%) [R404]
34	VRD-RA2EE563J	AA	N	C	Resistor (1/4W 56K Ω \pm 5%) [R706]

8 Resistors

NO.	PARTS CODE	PRICE RANK	NEW MARK	PART RANK	DESCRIPTION
35	VRD-RA2EE682J	AA		C	Resistor (1/4W 6.8KΩ ±5%) [R515]
36	VRD-RA2EE683J	AA	N	C	Resistor (1/4W 68KΩ ±5%) [R605]
37	VRD-RA2EE684J	AA	N	C	Resistor (1/4W 680KΩ ±5%) [R608]
38	VRD-RA2EE820J	AA		C	Resistor (1/4W 82Ω ±5%) [R614,525]
39	VRD-RA2EE821J	AA	N	C	Resistor (1/4W 820Ω ±5%) [R860,861]
40	VRD-RA2EE822J	AA		C	Resistor (1/4W 8.2KΩ ±5%) [R604]
41	VRD-RA2EE824J	AA		C	Resistor (1/4W 820KΩ ±5%) [R708]
42	VRD-RA2HD1R0J	AA	N	C	Resistor (1/2W 1.0Ω ±5%) [R524]
43	VRD-RA2HD471J	AA	N	C	Resistor (1/2W 470Ω ±5%) [R530]
44	VRD-RA2HD6R8J	AA	N	C	Resistor (1/2W 6.8Ω ±5%) [R615-618]
45	VRD-RA2HD102J	AA	N	C	Resistor (1/2W 1.0KΩ ±5%) [R521]
46	VRD-RA2HD3R9J	AA		C	Resistor (3.9Ω 1/2W ±5%) [R508]
47	VRD-RA2HD391J	AA	N	C	Resistor (1/2W 390Ω ±5%) [R519]
48	VRD-RA2HD221J	AA	N	C	Resistor (1/2W 220Ω ±5%) [R528]
49	VRD-RA2HD5R6J	AA	N	C	Resistor (1/2W 5.6Ω ±5%) [R518]
50	VRD-RA2HD101J	AA	N	C	Resistor (1/2W 100Ω ±5%) [R529]
51	VRD-RU2EE151J	AA	N	C	Resistor (1/4W 150Ω ±5%) [R855,857]
52	VRD-RU2EE470J	AA		C	Resistor (1/4W 47Ω ±5%) [R850]
53	VRD-RU2EE821J	AA	N	C	Resistor (1/4W 820Ω ±5%) [R862]
54	VRN-RU3AA47J	AB		C	Resistor (1W 0.47Ω ±5%) [R627]
55	VRN-RU3AA3R9J	AB	N	C	Resistor (1W 3.9Ω ±5%) [R527]
56	VRS-PU2HB151J	AA		C	Resistor (1/2W 150Ω ±5%) [R704]
57	VRS-PU2HB820J	AA	N	C	Resistor (1/2W 82Ω ±5%) [R506]
58	VRS-PU3AB271J	AA		C	Resistor (1W 270Ω ±5%) [R401]
59	VRS-PU3AB391J	AA		C	Resistor (1W 390Ω ±5%) [R520]
60	VRS-PU3AB392J	AA		C	Resistor (1W 3.9KΩ ±5%) [R406]
61	VRS-PU3AB562J	AA		C	Resistor (1W 5.6KΩ ±5%) [R866-868]
62	VRS-PU3AB821J	AA		C	Resistor (1W 820Ω ±5%) [R631]
63	VRS-PU3DB101J	AA		C	Resistor (2W 100Ω ±5%) [R484]
64	VRS-PU3DB122J	AA		C	Resistor (2W 1.2KΩ ±5%) [R613]
65	VRS-PU3DB392J	AB		C	Resistor (3.9KΩ 2W ±5%) [R523]
66	VRS-PU3DB331J	AB		C	Resistor (2W 330Ω ±5%) [R705]
67	VRS-PU3DB822J	AB		C	Resistor (2W 8.2KΩ ±5%) [R612]
68	VRS-PV3AB561J	AA		C	Resistor (1W 560Ω ±5%) [R630]
69	VRW-KV3HC1R8K	AC		C	Resistor (5W 1.8Ω ±10%) [R701]
70	VRD-RA2HD152J	AA	N	C	Resistor (1/2W 1.5KΩ ±5%) [R522]

9 Miscellaneous parts

NO.	PARTS CODE	PRICE RANK	NEW MARK	PART RANK	DESCRIPTION
1	PMAGF3003CEZZ	AK		C	Magnet
2	PRDAF0221TAZZ	AG	N	C	Heat sink [Q501,502 YO]
3	PRDAF0222TAFW	AG	N	C	Heat sink [Q501,502 YO]
4	PRDAR1126CEFW	AE	N	C	Heat sink [Q602 H-OUT-YO]
5	PRDAR5018CEZZ	AB	N	C	Heat sink [SCR YO]
6	PSLDM0384TAZZ	AA	N	C	Shield
7	PZETV0007TAZZ	AA	N	C	Insulator
8	PZETV0109TAZZ	AF	N	C	Insulator
9	QACCB0011TAZZ	BB		D	AC cord(U.K. only)
10	QACCZ0026TAZZ	AY		D	AC cord(EUROPE except U.K.)
11	QCNCW-0348TAZZ	BB			Connecting cord
12	QFS-C1621TAZZ	AE		A	Fuse (1.6A) [F701]
13	QFSDH1002CEZZ	AA		C	Fuse holder [F702-YO]
14	QPLGN0109TAZZ	AC	N	C	Plug (3pin-SW)
15	QPLGN0207CEZZ	AA		C	Plug (2P)
16	QPLGN0213GEZZ	AA		C	Plug (LED-YO)
17	QPLGN0304CEZZ	AB		C	Plug (3pin AC-YO)
18	QPLGN0403CEZZ	AB		C	Plug (4P-PLG)
19	QPLGN0408CEZZ	AB		C	Plug (4pin PT)
20	QPLGN0505CEZZ	AB		C	Plug (DY YO)
21	QS0CA0016TAZZ	AK		C	Socket AC-INLET
22	QS0CN0102CEZZ	AA	N	C	Socket
23	QS0CN0210GEZZ	AB	N	C	Socket (2pin-LED)
24	QS0CN0302CEZZ	AA	N	C	Socket
25	QS0CV1425CEZZ	AH		C	Socket
26	QSPGC0010CEZZ	AB		C	Spark gap
27	QSPGC0011CEZZ	AC		C	Spark gap
28	QSPGH0013CEZZ	AF		C	Spark gap
29	QSW-P0047TAZZ	AN		C	Push switch [SW750]
30	QTANZ0013TAZZ	AG	N	C	Terminal

10 Mechanical parts

NO.	PARTS CODE	PRICE RANK	NEW MARK	PART RANK	DESCRIPTION
1	LANGB0111CEFD	AC	N	C	Fixing metal
2	LANGK0210CEZZ	AE	N	C	Fixing metal
3	LANGQ1170CEZZ	AB	N	C	Fixing metal
4	LANGR9038CEZZ	AE	N	C	Fixing metal
5	LANGR9039CEZZ	AS	N	C	Fixing metal
6	LANGT9159CEZZ	AB	N	C	Fixing metal

10 Mechanical parts

NO.	PARTS CODE	PRICE RANK	NEW MARK	PART RANK	DESCRIPTION
7	LANGT9344CEZZ	AH	N	C	Fixing metal
8	MSPRT0001CEFJ	AA	N	C	Spring
9	PCAPH1010CEZZ	AF		C	Cap
10	PCAPH8013CEZZ	AC	N	C	Cap

11 Screws,Nuts,Washers and Wire holder

NO.	PARTS CODE	PRICE RANK	NEW MARK	PART RANK	DESCRIPTION
1	LHLDWF1016CEZZ	AB	N	C	Holder
2	LHLDW1013TAZZ	AB	N	C	Holder
3	LHLDW1033CE00	AA	N	C	Holder
4	LHLDW1037CEZZ	AA	N	C	Holder
5	LHLDW1046CEZZ	AA	N	C	Holder
6	LHLDW9003TAZZ	AA		C	Holder (8din-cable YO)
7	LX-BZ3086CEFD	AA	N	C	Screw
8	LX-CZ3002CEFD	AA	N	C	Screw
9	LX-NZ0023TAFD	AA	N	C	Nut
10	LX-NZ3014CEFN	AA	N	C	Nut
11	LX-NZ3043CEFD	AA	N	C	Nut
12	LX-NZ3062CEZZ	AA	N	C	Nut
13	PSPAG0001CE00	AA	N	C	Spacer
14	PSPAG0023CEZZ	AC		C	Spacer
15	XCASC40P25000	AA		C	Screw
16	XCASD30P08000	AA		C	Screw
17	XCASD30P10000	AA	N	C	Screw
18	XCASD30P12000	AA	N	C	Screw
19	XCASD40P10000	AA	N	C	Screw
20	XTASD30P10000	AA	N	C	Screw
21	XTASD40P12000	AA	N	C	Screw
22	XTASD40P16000	AA		C	Screw
23	XTASD40P25000	AA	N	C	Screw
24	XTBSD50P20000	AA	N	C	Screw
25	XUASC40P20000	AA		C	Screw
26	XWHS45-12150	AA	N	C	Washer
27	XWSPN30-06000	AA	N	C	Washer(AC-Inlet)
28	GNETC0037CEZZ	AD	N	C	Net
29	PCLIC1003CEZZ	AA	N	C	Clip
30	QLUGP0102CEFW	AA		C	Lug
31	QLUGP0104TAFW	AA	N	C	Lug
32	QLUGP0105CEFW	AA	N	C	Lug
33	QLUGZ0105CEZZ	AA	N	C	Lug
36	QTIPF0001CEFM	AA	N	C	Tip
37	QTIPM0005CEZZ	AA	N	C	Tip
38	QTIPM0007CEZZ	AA	N	C	Tip
39	QTIPM0008CEZZ	AA	N	C	Tip
40	QTIPM0010GEZZ	AB	N	C	Tip
41	RRET-0053CEZZ	BG		B	Rectifier unit
42	SPAKA6416TAZZ	AM		D	Packing add.

12 Cabinet parts

NO.	PARTS CODE	PRICE RANK	NEW MARK	PART RANK	DESCRIPTION
1	GCABA1390CESA	BD	N	D	Cabinet
2	GCABB1343CESF	BH	N	D	Cabinet
3	GC0VH7043TAZZ	AC	N	D	Cover
4	HBDGB1002CESA	AD		D	Badge(SHARP badge)
5	HBDGC0016TASA	AC		D	Badge
6	HDECC0039CESB	AD		D	Decoration plate
7	JBTN-1104CEKB	AE		D	Button
8	TCAUA0057TAZZ	AD	N	D	Caution card
9	TCAUS0386TAZZ	AB		D	Caution card
10	TCAUS0417TAZZ	AC	N	D	Caution card
11	TLABK0001TAZZ	AA		D	Label
12	TLABM0243TAZZ	AC	N	D	Label
13	TLABM0997TAZZ	AC	N	D	Label(U.K. only)
14	TLABM0998TAZZ	AC	N	D	Label(EUROPE except U.K.)
15	TLABN0022TAZZ	AA		D	Label
16	TLABS0039TAZZ	AB	N	D	Label
17	TLABS0041TAZZ	AB	N	D	Label

13 The others parts

NO.	PARTS CODE	PRICE RANK	NEW MARK	PART RANK	DESCRIPTION
1	SPAKC7011TAZZ	AT	N	D	Packing case(EUROPE except U.K.)
2	SPAKC7010TAZZ	AT	N	D	Packing case(U.K. only)
3	SPAKP6416TAZZ	AE		D	Wrapping paper
4	SSAKA0003GEZZ	AA		D	Vinyl bag
5	TINSZ7011TAZZ		N	D	Instruction book